



WATER SOFTENER ALTERNATIVE
WITH NATURSOFT® SALT-FREE TECHNOLOGY



TABLE OF CONTENTS

IMPORTANT INFORMATION	2
WATER CONDITIONS FOR OPERATION	2
CUSTOMER SERVICE CONTACT INFORMATION	2
PRODUCT OPERATION AND SPECIFICATIONS	3
COMPLETE PARTS LIST	3
INSTALLATION	
INSTALLATION OVERVIEW	4
PRE-INSTALLATION	5
MEDIA SOAK	6
SEDIMENT FILTER INSTALLATION	7
WATER SOFTENER ALTERNATIVE TANK INSTALLATION	8
BYPASS VALVE OPERATION	9
COMPLETE THE INSTALLATION	9
WHAT TO EXPECT WITH YOUR NEW WATER SOFTENER ALTERNATIVE	10
MAINTENANCE	11
TROUBLESHOOTING	12
PRODUCT CERTIFICATIONS	13

IMPORTANT INFORMATION

- Read these instructions carefully and determine the location of all system components before beginning installation.
- Check all applicable plumbing, building, and electrical codes for installation compliance.
- Install the system on the main water supply.
- The use of plumber's tape and/or Pipe Thread Seal Paste will be needed on all threaded connections.
- To condition all water in the home, install the water softener alternative close to the water supply inlet, and upstream of all other plumbing connections, except outside water pipes. Outside faucets should remain on hard water to avoid wasting conditioned water.

WARNING

If this or any other system is installed in a metal (conductive) plumbing system, i.e. copper or galvanized metal, the plastic components of the system will interrupt the continuity of the plumbing system. As a result any errant electricity from improperly grounded appliances downstream or potential galvanic activity in the plumbing system can no longer ground through contiguous metal plumbing. Some homes may have been built in accordance with building codes, which actually encouraged the grounding of electrical appliances through the plumbing system. Consequently, the installation of a bypass consisting of the same material as the existing plumbing, or a grounded "jumper wire" bridging the equipment and re-establishing the contiguous conductive nature of the plumbing system must be installed prior to your systems use.

CAUTION

When adding this system to homes/buildings supplied by well water, the system should be installed following the pressure tank. **DO NOT USE this system for pneumatic or hydro-pneumatic applications. If you are using a booster pump, then install this system following the booster pump.** If you have questions, please call customer service.

WATER CONDITIONS FOR OPERATION

- The water should be free of hydrogen sulfide, a dissolved gas with a characteristic smell of rotten eggs. If present, it can coat the catalytic surface of the media and interfere with the process. The gas should be removed through adequate pre-treatment.
- The water should be free of hydrocarbons, oils, and lubricants. If present, they can coat the catalytic surface of the media and interfere with the process. Remove through adequate pre-treatment.
- The water should contain less than 1 mg/l of phosphates.
- The copper level in the water supply should be below the MCL of 1.3mg/L. If copper is present above this level, it can attach to the surface of the media and interfere with the process.

Customer Service Contact Information Section

Homeowners Phone: 877.842.1635

Professionals Phone: 877.842.1635





PRODUCT OPERATION AND SPECIFICATIONS

Specification Description	NS3-P	NS6-P
Max Flow Rate	10 GPM	15 GPM
Minimum Working Pressure	25 PSI	
Maximum Working Pressure	80 PSI	
Maximum Vacuum	5 inch/127 mm Hg	
Operating Temperatures	36°F - 120°F	
pH Range	7 - 11	

The WATER SOFTENER ALTERNATIVE WITH NATURSOFT® SALT-FREE TECHNOLOGY may be effective on water supplies with a maximum hardness of 75 Grains per Gallon (GPG) or 1,282 ppm. For best results, all iron/manganese, sulfur and tannins should be removed prior to this system's installation. To ensure a proper system application, we recommend having your water professionally tested by Pentair or any other qualified water testing organization prior to installing this system.

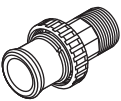
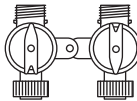
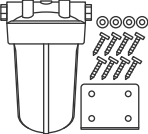
COMPLETE PARTS LIST

Note: The parts supplied are intended to accommodate a variety of water supply lines. Additional fittings may be needed to fit to your plumbing. Visit pentair.com to view our full line of installation kits.

Part	Description	Qty.	Part	Description	Qty.
	1" Plastic Male NPT Assembly: V3007-04 WS1 Fitting 1" Plastic Male NPT Assembly (2): O-Rings (2), Split Rings (2) and Connectors (2)	1		Bypass Valve: In/Out Bypass Valve with Red Arrow Handles	1
	Sediment Filter System: Blue Sediment Filter Housing, Mounting Bracket, Bolt Head Screws (8), Washers (4), O-Rings (2)	1		Sediment Filter 5 Micron Poly-Spun Sediment Filter	1
	Sediment Filter Wrench	1		Water Softener Alternative	1
	Non-Abrasive Auto Wax 4 oz. Bottle	1			

Note: Drawings are not to scale.

INSTALLATION OVERVIEW

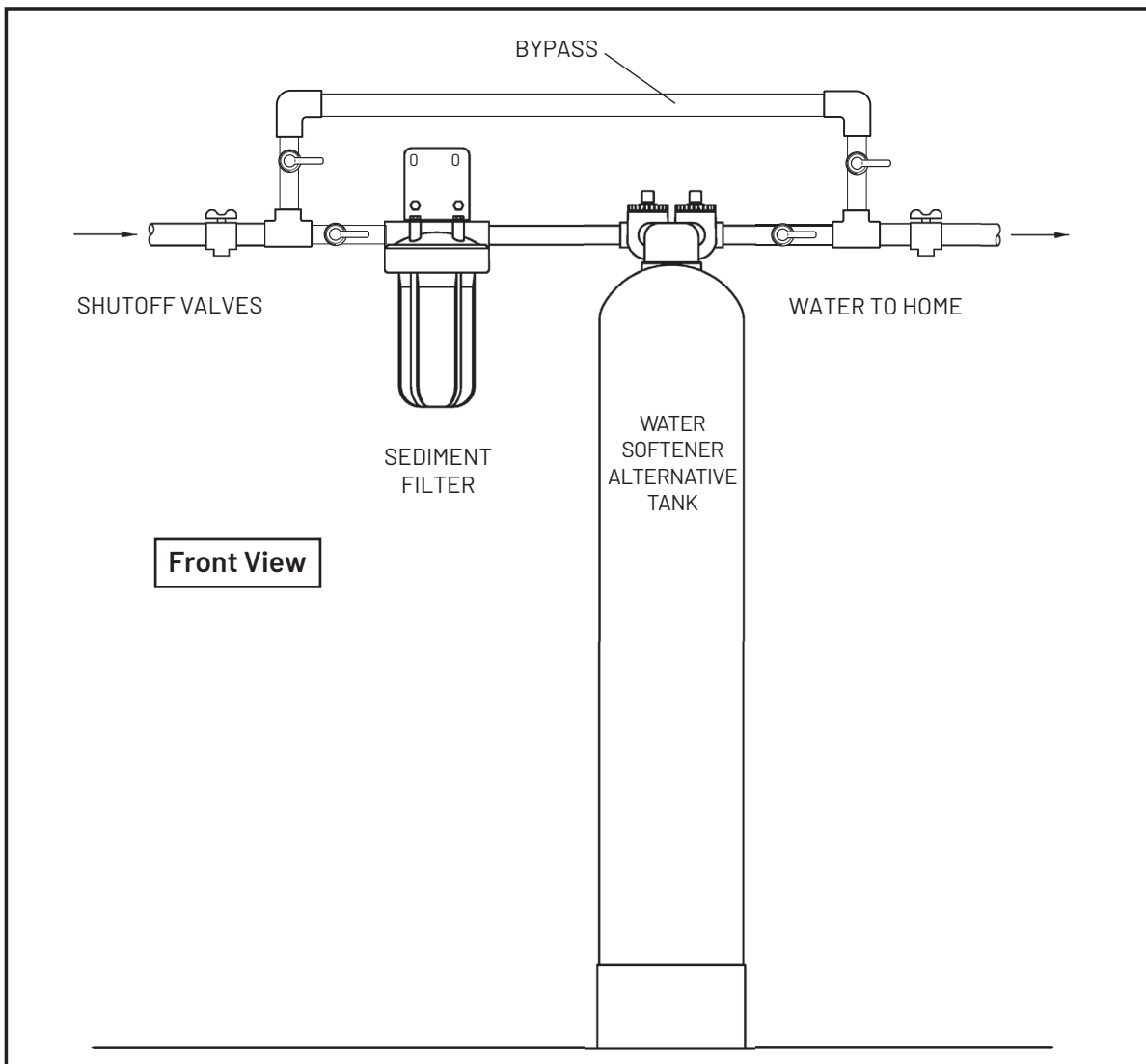
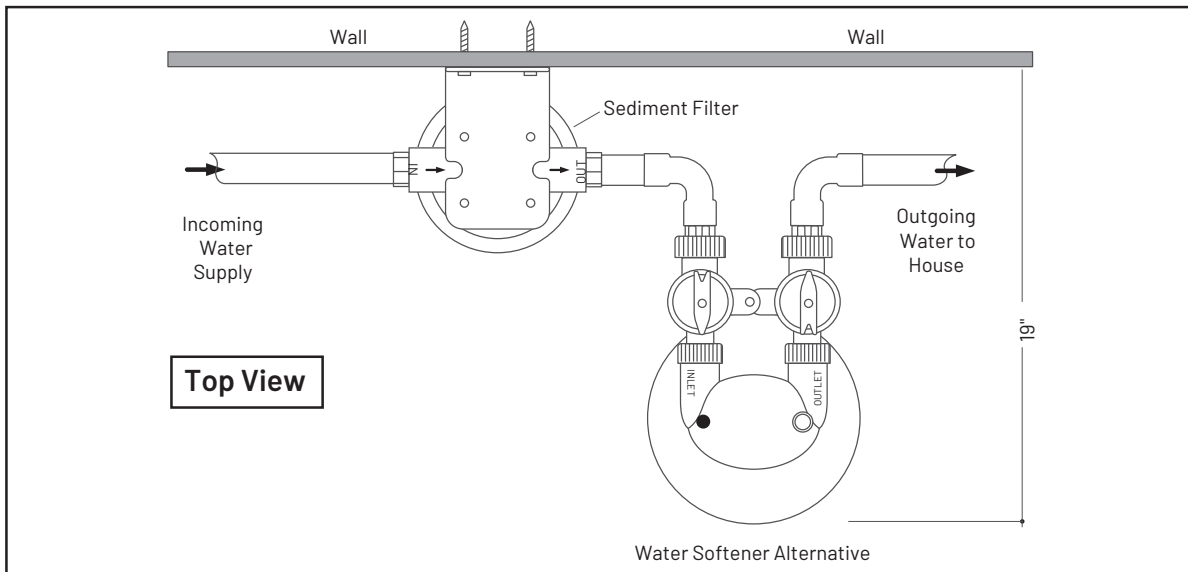

Note: Sediment filter position is at the discretion of your professional installer. As a general guideline, the sediment prefilter is typically installed in the "pre" position (as shown above) for well water applications. For city water applications, the sediment filter is typically installed in the "post" position after the Water Softener Alternative tank.

PRE-INSTALLATION

Notice: Head may come loose in transit. Please check head by tightening clock wise, hand tighten only, no more than ¼ turn. Head may not move at all or less than ¼ turn.

Bypass Valve Installation

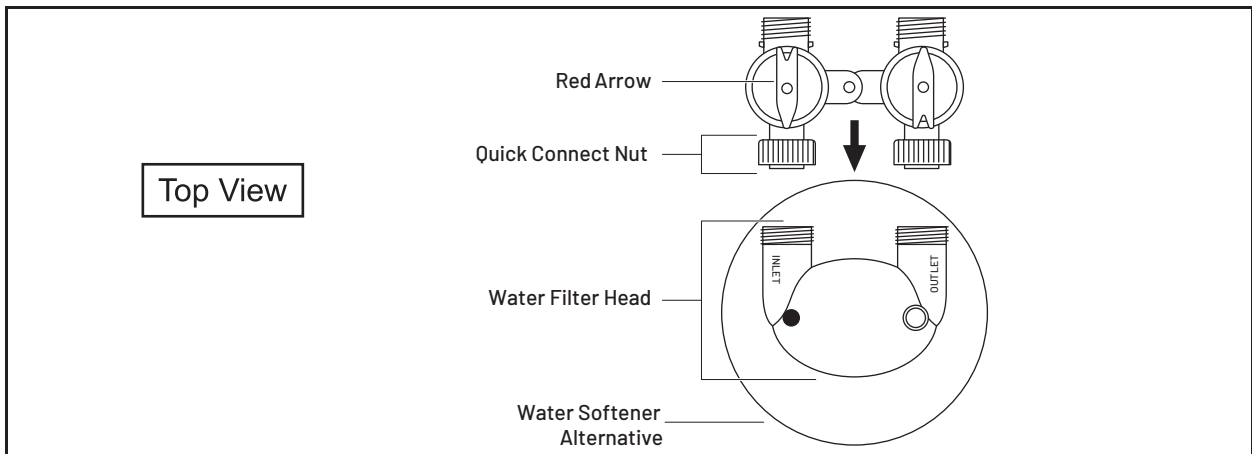

Figure 2

The bypass valve comes pre-assembled and ready to install with the o-rings, split rings, and quick connect nuts. Push the bypass valve into the head of the NaturSoft® Water Softener Alternative with the unthreaded ends oriented toward the tanks and hand-tighten the quick connect nuts.



Notice

The bypass valve(s) included with this system are designed for multiple water systems. This may result in the arrows on the bypass valve(s) pointing differently than shown. If the arrows on your bypass valve(s) do not match the diagram, remove the red arrows by pulling them straight up, turn them 180° to match the drawing, and push them back down onto the stem.

MEDIA SOAK

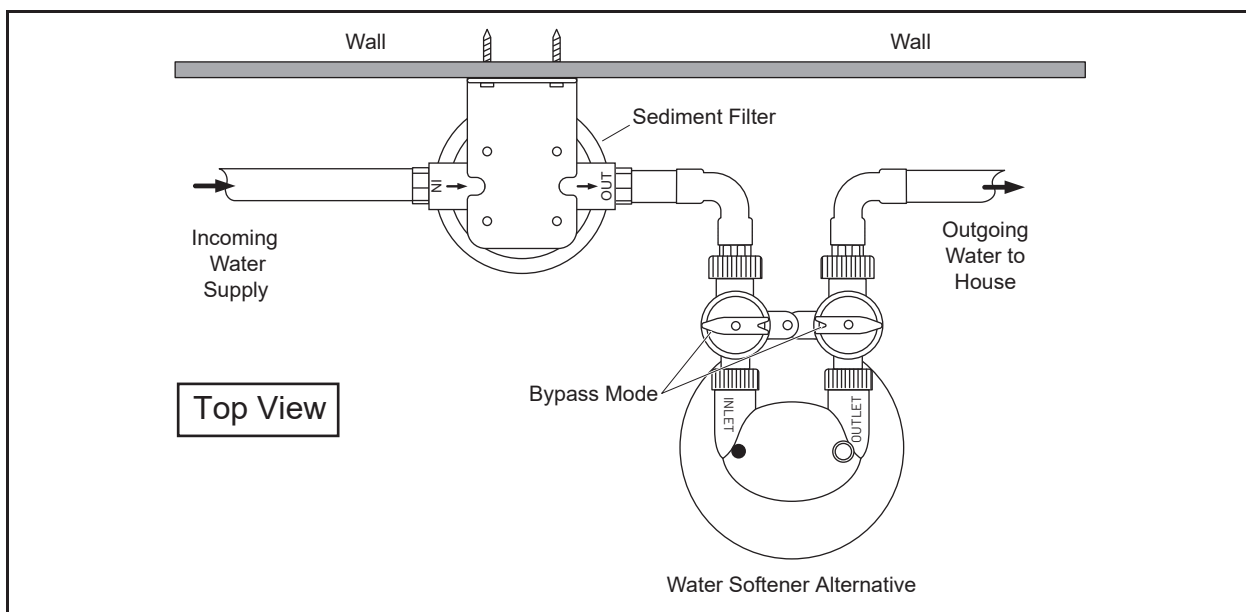

Caution

NaturSoft® - Media Soak:

The Natursoft Water Softener Alternative **MUST** be in the bypass position during this process (see Figure 9).

1. Open a cold water faucet or test spigot close to the downstream of the Water Softener alternative.
2. Turn the water back on at the main shut-off valve allowing the system to fill with water. The air being displaced will escape through the open fixture downstream.
3. Turn the arrows on the Bypass Valve of the NaturSoft® Tank into the Bypass Mode position to bypass the tank. This will allow you to isolate the system and restore water supply to the home/ building during the NaturSoft® media soak.
4. Allow the tank to soak for at least 60 minutes.

Caution

NaturSoft® - Media Flush:

The Natursoft Water Softener Alternative **MUST** be in the bypass position during this process (see Figure 9).

1. After the tank has soaked for 60 minutes, turn the main water supply back on or turn the arrows on the Bypass Valve back into their original position.
2. Flush the system by running water for 5 minutes at a high flow rate of 5 GPM (this can be achieved by using a bath tub or more than three (3) faucets).
Note: The flush water may have a milky look to it. This is normal as calcium carbonate fines are flushed from the system.
3. Rinse the system by reducing the flow rate to ½ GPM and run water for 60 minutes (this can be achieved by turning one faucet ¼ of the way on).
4. Turn the Whole House Water Filter Bypass Valve to the on position (out of Bypass Mode).

SEDIMENT FILTER INSTALLATION

Note: Sediment filter position is at the discretion of your professional installer. As a general guideline, the sediment pre filter is typically installed in the "pre" position (as shown above) for well-water applications. For city water applications, the sediment filter is typically installed in the "post" position after the Water Softener Alternative tank.

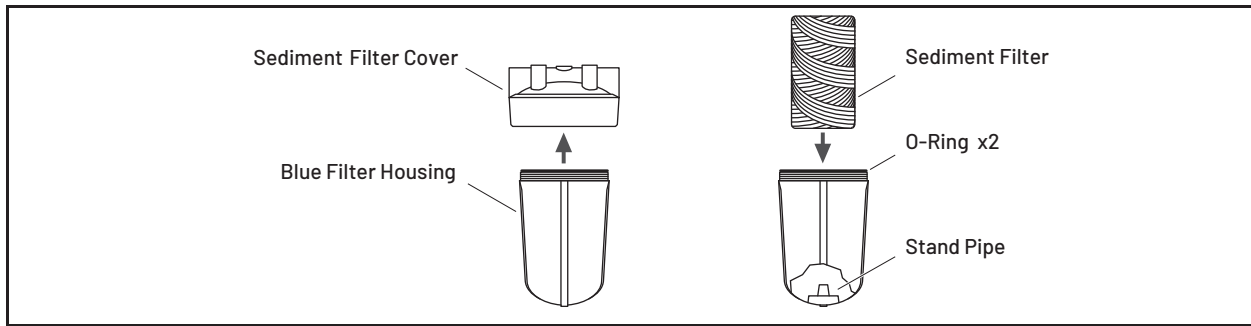

Part 1

1. Unscrew the cover from the blue filter housing.
2. Remove the plastic covering from the sediment filter.
3. Place the sediment filter onto the stand pipe in the blue filter housing and set aside.

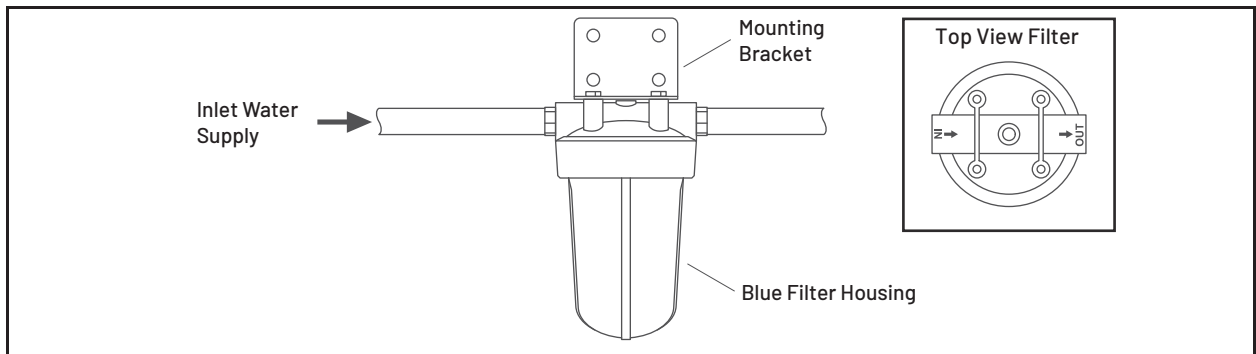

Part 2

1. Shut off the water.
2. Attach the filter cover to the mounting bracket using the supplied bolt head screws and washers. Make sure to properly orientate the IN and OUT to match your flow pattern.
3. Attach the mounting bracket to the wall using the supplied bolt head screws.
4. Hand tighten the blue filter housing and then, using the supplied filter wrench, lightly snug the housing making sure not to over-tighten (counterclockwise).
5. Determine the size of your inlet water supply line.

WATER SOFTENER ALTERNATIVE TANK INSTALLATION

1. Level the Water Softener Alternative

Note: See "Troubleshooting" section on tips for leveling the tank.



Notice

If the tank is not level, lift the tank straight up 6 inches and tap it on the ground until the tank stands vertical. The bottom of the tank is round and the boot allows the tank to stand upright.

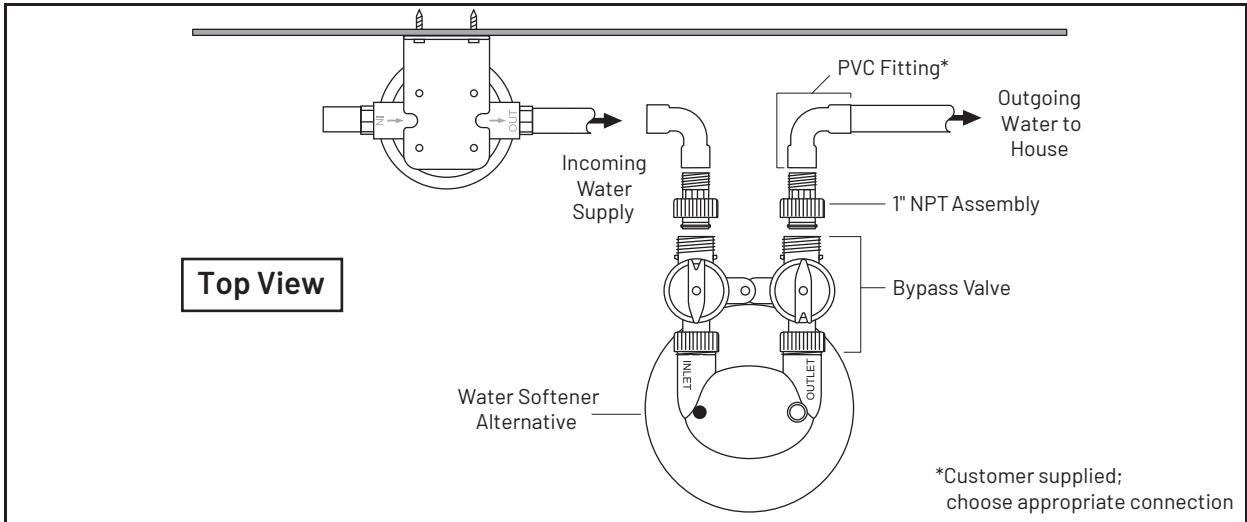

2. Determine the size and material of your incoming water supply line and choose the appropriate plumbing required to adapt to the 1" male NPT Assembly.

Note: Visit Pentair.com to view our full line of installation kits.



Caution

Do not over-tighten any of the fittings during installation.

Note: The fitting below is designed with a 1/4" give to allow for proper pipe alignment. It will not leak and is intended to have some flexibility.

Part	Description	Qty.
	1" Plastic Male NPT Assembly: V3007-04 WS1 Fitting 1" Plastic Male NPT Assembly (2); O-Rings (2), Split Rings (2), and Connectors (2)	1 bag

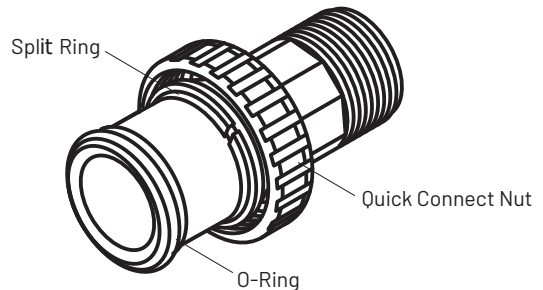

3. Install the fittings into the INLET and OUTLET sides of the bypass valve. Follow the diagram supplied with the fitting.
4. Connect the incoming water supply from the sediment filter to the fitting on the INLET side of the bypass valve.
5. Connect the outgoing water supply to the OUTLET side of the bypass valve.

BYPASS VALVE OPERATIONS

Figure A shows the system "in service" which allows water to flow in and out of the tank. In this position the system would be considered ON.

In Service

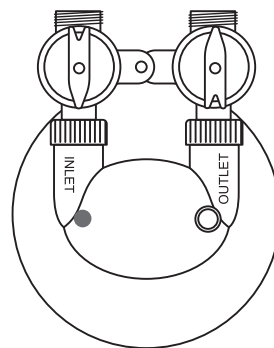

Figure A

Figure B shows the system "in bypass" which will direct water straight to the home without going in and out of the tank. In this position the system would be considered OFF.

In Bypass

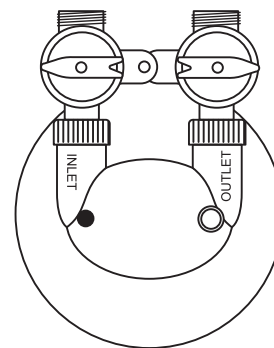
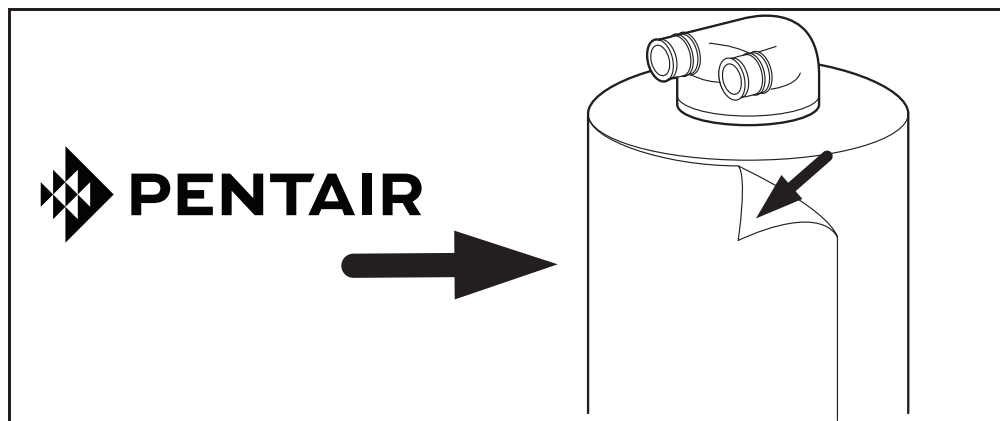

Figure B

COMPLETE THE INSTALLATION



1. Check for leaks.
2. Peel off the protective plastic wrap from the stainless steel tank jacket(s).
3. Add the Pentair logo sticker(s) in the desired location on the tank.
4. Wax stainless steel tank jacket(s) with wax provided (or any other non-abrasive auto wax) a minimum of 1-2 times per year or as needed based on the installed environment.

Clean your Hot Water Heater

Cleaning and restoring the plumbing system can be a benefit of the NS3-P / NS6-P NaturSoft® system. In order to minimize the time required to complete the decaling process, we strongly recommend cleaning your hot water heater 3 weeks after installation of your water softener alternative system.

- Turn off the heat source, attach a hose to the drain valve at the bottom of the tank and flush the heater by opening the drain valve. After the water heater is completely filled with water, turn the heat source back on.

WHAT TO EXPECT WITH YOUR NEW WATER SOFTENER ALTERNATIVE SYSTEM

If you have never had a water softener or water softener alternative:

Immediately after the installation you will experience conditioned water. Most detergents may work better with treated water and you may be able to reduce the amount you use. However, there are mineral deposits and hard water scale coating the inside of your pipes and fixtures. Over the first few weeks, this hard water scale will dissolve, detach itself from the pipes, and come out of your faucets. This de-scaling process is temporary and will steadily diminish. During these first weeks, you may notice:

- **Reduced softness of the water.** This will be particularly evident when using hot water. The water can pick up more than ten grains of mineral content per gallon between the water softener alternative system and the faucet as it travels through the water heater and the plumbing.
- **Mineral silt in the water.** Since the existing limestone scale is softened and dissolved as part of the water softener alternative effect, it may detach in small chunks ranging in size from very fine silt to pieces larger than a grain of sand. The larger pieces may be big enough to build up in the aerator screens of your fixture. Considerable silt-like accumulations may be visible on the shower heads, so clean them weekly for the first four weeks. Higher flow rates will shear off more of the existing hard water scale than will lower flow rates. De-scaling activity can be most obvious in bathtubs, which have high flow and hot water. You may see milky water with sand-like grit, and possible sediment or iron in the bath tub.
- **The water line supplying fixtures which experience the most use will be cleaned the quickest and can be the first to return to providing you the full benefits you experienced immediately following installation; rarely used fixtures will take longer.**

If you had a traditional water softener:

A traditional water softener turns dissolved mineral hardness (calcium bicarbonate) into dissolved sodium bicarbonate. The water softener alternative technology maintains the mineral content of the water without adding the bicarbonate. You will notice:

- **In a traditional water softener,** the absence of the calcium and the presence of sodium bicarbonate makes the water feel slick and slimy. If you miss the slick feeling, add some baking soda (sodium bicarbonate) to your bath water.
- **The water spots are more visible.** A water softener replaces calcium with sodium. The water spotting that a traditional water softener leaves behind is a salt haze that wipes off very easily and is far less noticeable than spots caused by minerals. The water softener alternative treatment results in reduced spotting compared to untreated water, but more visible spots than produced by traditional, chemically treated softened water. The water softener alternative mineral spots are much easier to clean than spots from untreated water.
- **Soap curd forms with certain products.** Oil-based soaps like Ivory will react with calcium minerals to form a sticky film. Detergent-based cleaners like shampoos, shower gels, dish soaps, and laundry detergents will react very slightly or not at all. Most detergent will work better with treated water, but you will notice very little improvement when using regular bar soap or oil-based products since the minerals are largely still able to react with the fats in the soap to form the curd.
- **There is some mineral silt in the bathtub.** Depending on the water chemistry of your water supply, you may still have some hard water scale deposits in your plumbing system.

If you have a dishwasher:

The water softener alternative system can cause the hard water minerals to remain in the water instead of attaching to pipes and appliances. Harsh chemicals, specifically acidic (low pH) detergents or rinse agents, can dissolve the hard water minerals, reducing their desired effect. For this reason, you should adjust the combination and amounts of detergents and rinse agents in your dishwasher. Gel packs offer a great alternative as they contain detergents and rinse agents in predetermined amounts.

If you have glass shower doors:

Years of untreated hardness can etch the surface of your glass allowing for soap scum and minerals to get stuck in your glass. We recommend cleaning the glass surface thoroughly with a de-scaling cleaner such as CLR then applying a few coatings of Rain-X to seal the pores on the glass surface. This process will fill the pores in the glass and allow the water to bead.

MAINTENANCE

Sediment Filter

It is recommended that the sediment filter be replaced every 6-12 months depending on the amount of sediment present in the water supply. If the system has been working properly and the pressure is slowing, it may be time to change the sediment filter. Check the sediment filter and replace if necessary.

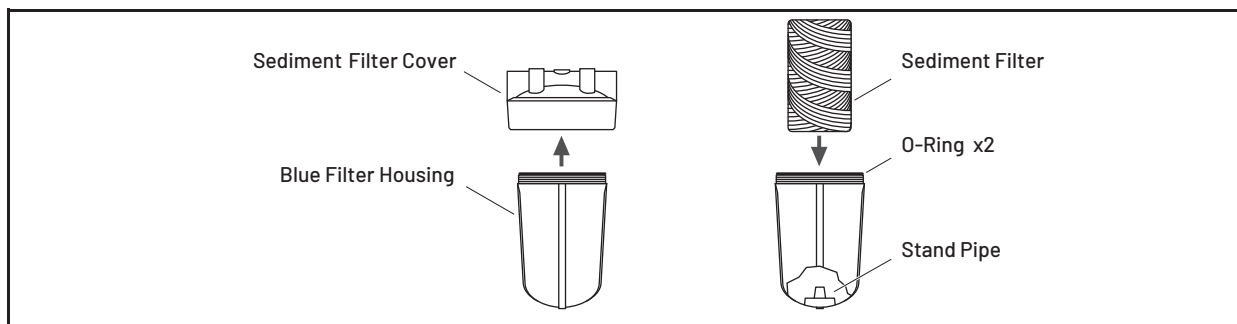

Replacing the Sediment Filter

1. Turn off the main water supply to the sediment filter system and bypass all tanks.
2. Run a faucet (cold water) inside the house to relieve the pressure. Leave the faucet open.
3. Unscrew the blue filter housing clockwise using the supplied filter wrench.
4. Remove the existing sediment filter and discard.
5. Remove the o-rings and wipe the upper groove clean. Lubricate two new o-rings with a coating of clean silicone grease. Replace both o-rings. Be sure to press the upper o-rings down into the groove with two fingers.

Note: This step is important to ensure the proper filter seal. Make sure the upper o-rings is seated level in the groove. If the o-ring appears damaged, stretched, or crimped it should be replaced.

6. Place a new sediment filter onto the stand pipe in the blue filter housing.
7. Screw the blue filter housing onto the filter cover hand tight. Lightly snug the housing with the spanner wrench making sure not to over-tighten.
8. Turn on the main water supply slowly to allow the sediment filter system to fill with water and expel air from lines. Put tanks back in service (out of bypass).
9. Check for leaks.

TROUBLESHOOTING

Problem	Solution
Water leaking at the top of the tank around the head.	You may need to turn the head to tighten it. The tank head is pre-installed hand-tight, do not overtighten the head (just turn it snug).
The tank leans to one side or is not level.	If the tank is not level, lift the tank straight up 6 inches and tap it on the ground until the tank stands vertical. The bottom of the tank is round and the boot allows the tank to stand upright.
<p>The diagrams illustrate the process of leveling the tank. The top row shows an unlevel tank (labeled 'Unlevel Tank') with a dashed line representing the water level. An upward arrow indicates lifting the tank, and a downward arrow indicates tapping it on the ground until it is level. The bottom row shows an unlevel tank (labeled 'Unlevel Tank') with an unlevel boot (labeled 'Unlevel Boot'). An upward arrow indicates lifting the tank, and a downward arrow indicates tapping it on the ground until the tank is level (labeled 'Level Tank') and the boot is unlevel (labeled 'Unlevel Boot').</p>	
Water pressure is slowing.	It is recommended that the sediment filter be replaced every 6-9 months depending on the amount of sediment present in the water supply. If the system has been working properly and the pressure is slowing, it may be time to change the sediment filter. Check the sediment filter and replace if necessary.

Notice: If you have experienced a Boil Alert or require your system to be sanitized, please go to pentair.com/assets/pwsboilalert for product sanitization instructions.

PRODUCT CERTIFICATION



NS3-P, NS6-P are certified By IAPMO R&T to NSF/ANSI 61 for material safety.

For Pentair Product Warranties visit: pentair.com/assets/residential-filtration-warranty



2361 Mason Ave | Suite 100 | Daytona Beach, FL 32117 | United States
P: 877.842.1635 | Technical Services: 877.842.1635 | pentair.com

All indicated Pentair trademarks and logos are property of Pentair. Third party registered and unregistered trademarks and logos are the property of their respective owners.
© 2022 Pentair. All rights reserved.
4006000 Rev B J122