

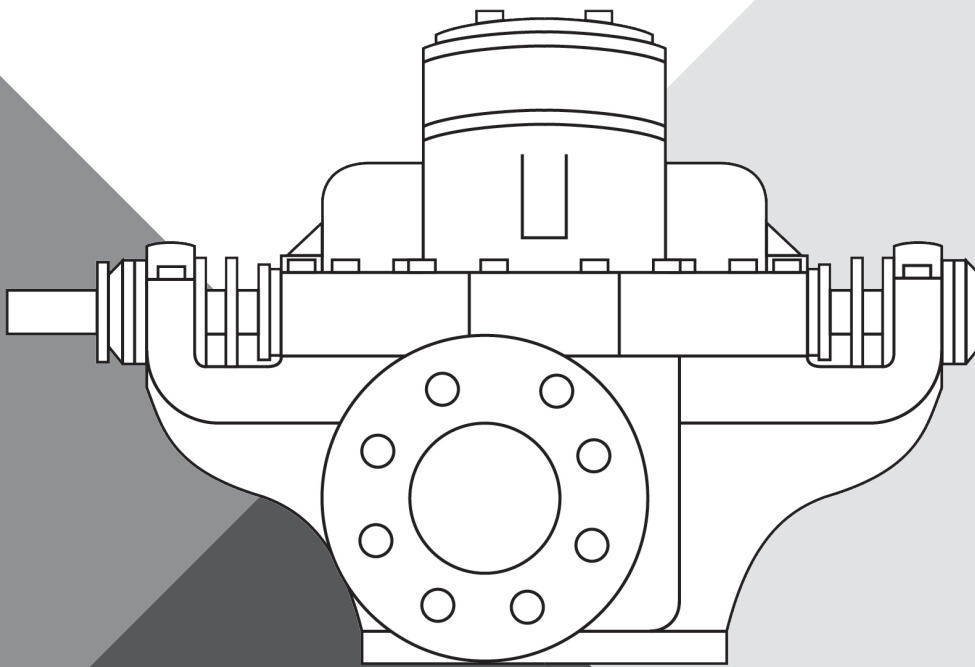

TWO STAGE VERTICAL & HORIZONTAL SPLIT CASE PUMPS

420 SERIES



REPAIR PARTS INDEX

pentair.com

TABLE OF CONTENTS

Pump Power Models 421, 422, & 423	3-5
2 x 2-1/2 x 12A, 2 x 2-1/2 x 12B, & 2-1/2 x 3 x 12A	6-7
3 x 4 x 14A, 3 x 4 x 14B, & 4 x 5 x 15	8-9
5 x 6 x 15.....	10
6 x 8 x 17A & 6 x 8 x 17B	11
Warranty.....	12

Note: Pumps are generally built in one of (5) five materials of construction:

- ◆ B.F. = BRONZE FITTED
- ◆ A.I. = ALL IRON
- ◆ S.F. = STANDARD FITTED
- ◆ S.S. = STAINLESS STEEL
- ◆ A.B. = ALL BRONZE

THE ONLY DIFFERENCE BETWEEN B.F. AND S.F. IS THE IMPELLER MATERIAL. B.F. PUMPS HAVE BRONZE IMPELLERS AND S.F. PUMPS HAVE CAST IRON IMPELLERS

SPLIT CASE MODEL DESIGNATIONS:

- ◆ Model 421 = Horizontal mounted 2 stage
- ◆ Model 422 = Vertical mounted 2 stage flexible shaft
- ◆ Model 423 = Vertical mounted 2 stage flex coupled

MODEL 421 PIECE NUMBERS

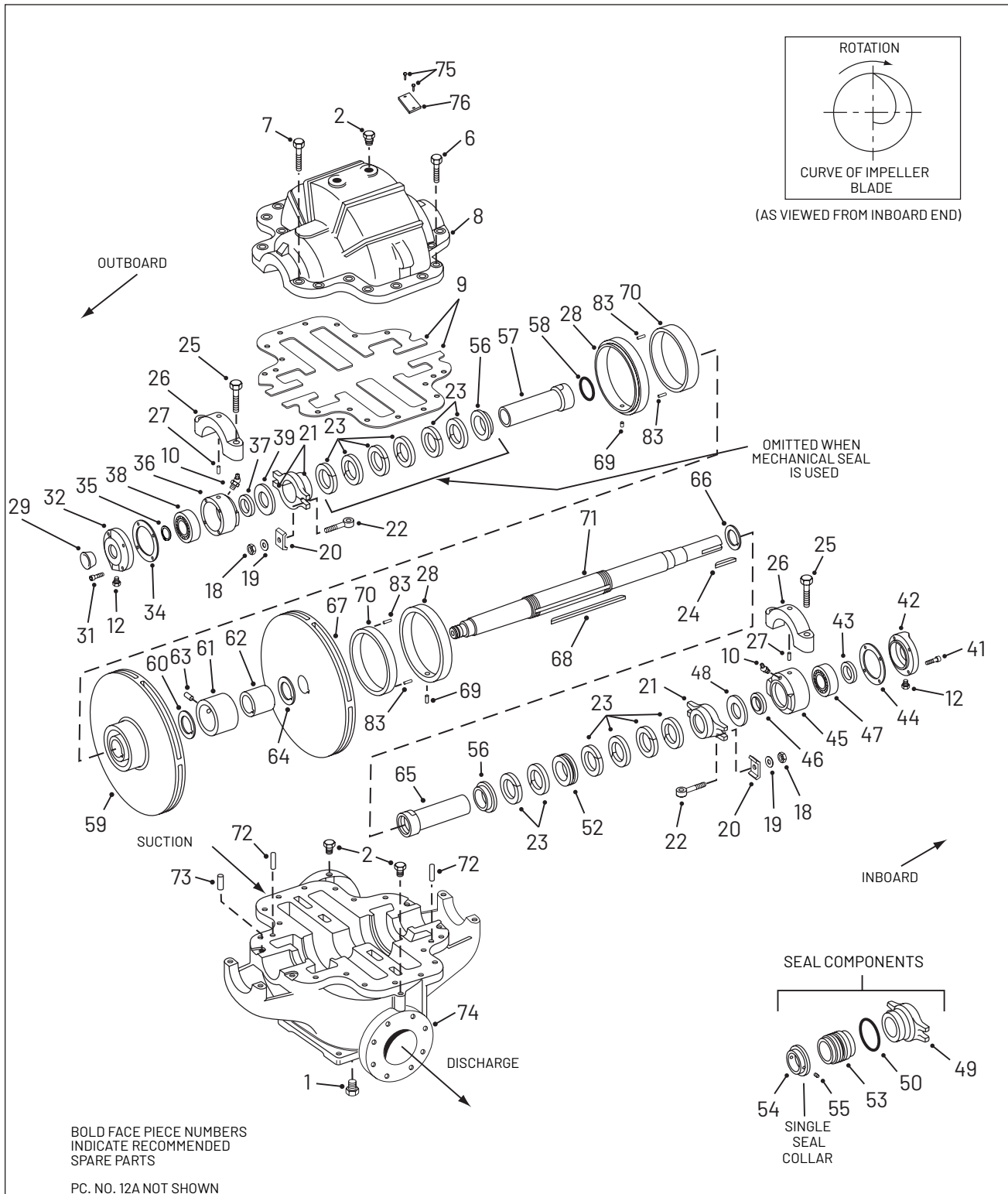

MODEL 422 PIECE NUMBERS

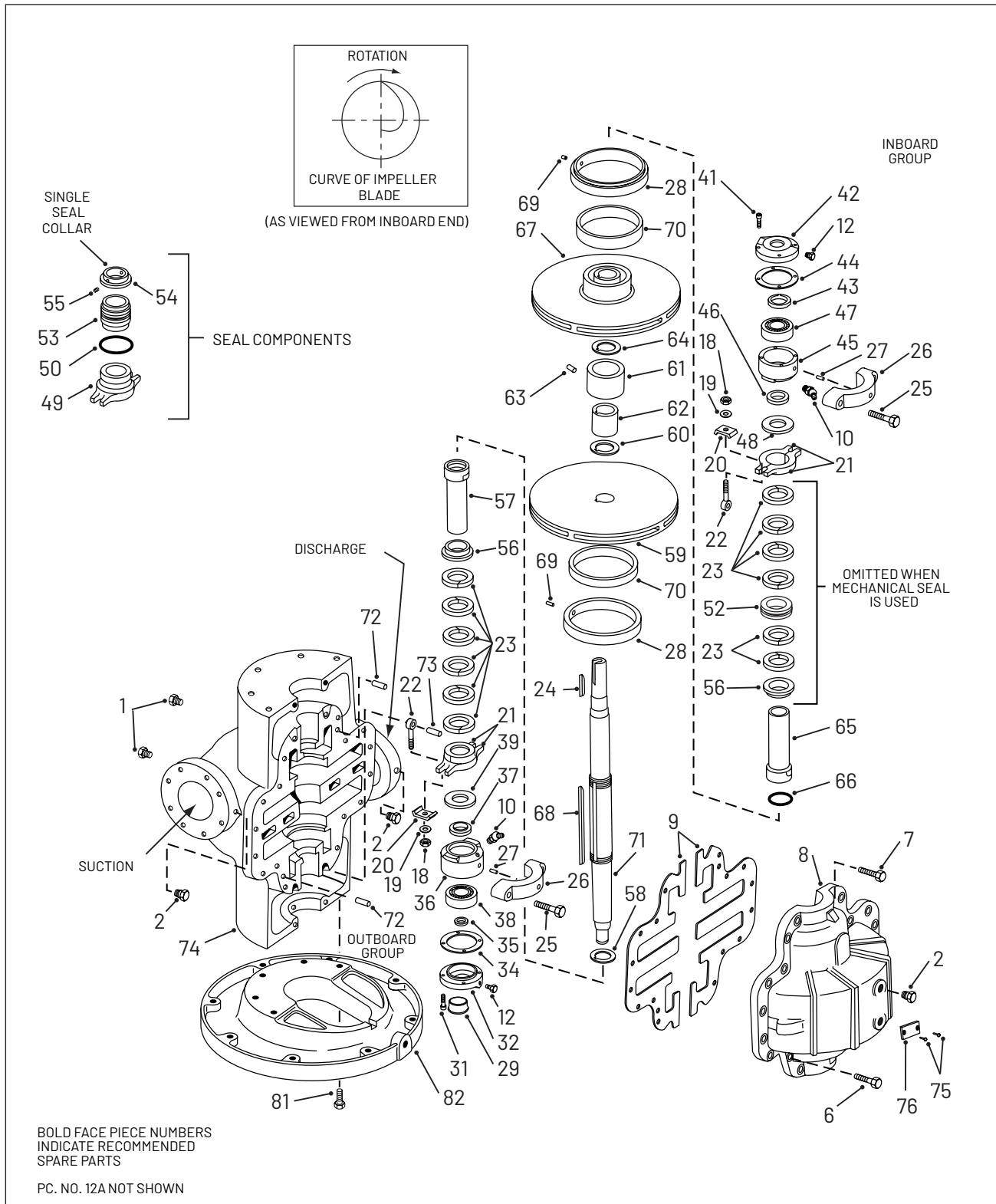

MODEL 423 PIECE NUMBERS

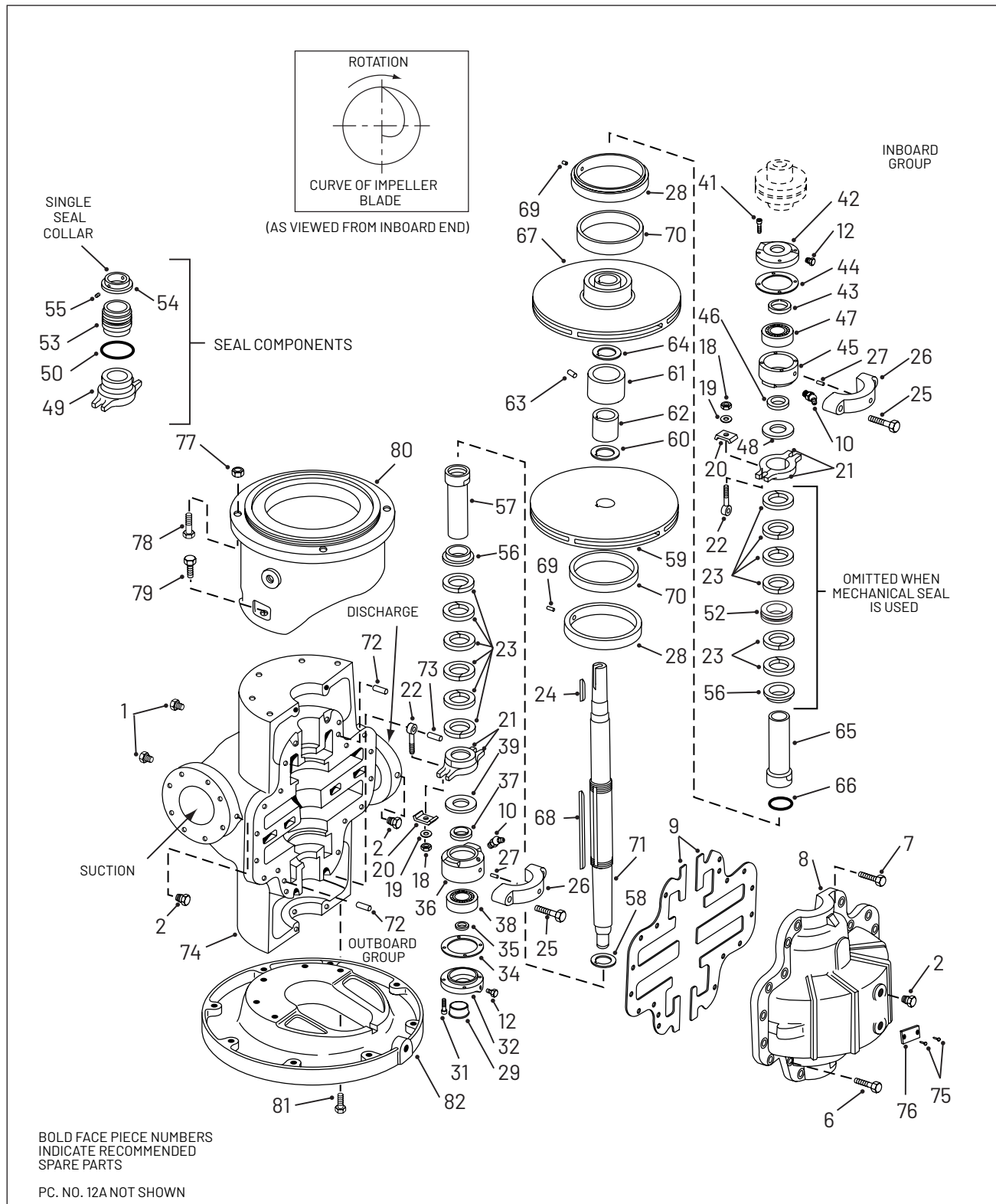

420 SERIES P.S. #2. MODELS 421-422-423 2 X 2-1/2 X 12A&B - 2-1/2 X 3 X 12A PARTS LIST

PC. NO.	DESCRIPTION	QTY	PART NO.	MATERIAL			
				B.F.	A.B.	A.I.	S.S.
1	PLUG MODEL 421	7	600-0003	087	190	087	104
	PLUG MODELS 422 & 423			REFER TO FACTORY			
2	PLUG	4	600-0002	087	190	087	104
6	CAPSCREW	16	168-0494	082	082	082	082
7	CAPSCREW			REFER PC NO. 73			
8	CASING			INCLUDED WITH PC NO. 74			
9	GASKET 2x2-1/2x12A&B	1	364-1220	598	598	598	598
	GASKET 2-1/2x3x12A	1	364-1221	598	598	598	598
10	GREASE FITTING	2	508-0015	651	651	651	651
12	PLUG	2	600-0001	087	087	087	087
18	NUT	4	544-0107	-	190	080	104
19	WASHER	4	908-0109	-	190	080	104
20	CLAMP	4	204-0120	-	190	360	104
21	GLAND(PACKING)	2	372-0225	010	208	010	104
22	SWING BOLT	4	100-0216		190	360	104
22A	SWING BOLT ASSY. (18, 19, 20, 22)	4	099-0002	644	-	-	-
23	PACKING	12	564-0151	802	802	802	802
24	KEY	1	472-0247	087	087	087	087
25	CAPSCREW	4	168-0494	082	082	082	082
26	BEARING CAP	2	163-0306	010		010	
27	PIN	2	592-0361	360	107	360	107
28	CASE RING:						
	2x2-1/2x12A	2	676-1007	208	208	010	107
	2x2-1/2x12B	2	676-1015	208	208	010	107
	2-1/2x3x12A	2	676-1015	208	208	010	107
29	PROTECTOR	1	624-0080	087	087	087	087
31	CAPSCREW	4	168-0015	082	082	082	082
	WATER COOL (OPT)	4					
32	CARTRIDGE CAP:						
	STANDARD	1	164-0531	010	010	010	010
	WATER COOLED	1	476-0745	644	644	644	644
34	GASKET	1	364-1309	614	614	614	614
35	RETAINER RING	1	676-0267	088	088	088	088
36	CARTRIDGE	1	176-0065	010	010	010	010
37	GREASE SEAL	1	712-6324	653	653	653	653
	OIL SEAL	1	712-0053	653	653	653	653
38	BEARING	1	068-0454	647	647	647	647
39	SLINGER	1	764-1017	478	478	478	478
41	CAPSCREW	4	168-0015	082	082	082	082
	WATER COOL (OPT)	4	168-0025	082	082	082	082
42	CARTRIDGE CAP						
	STANDARD	1	164-0531	010	010	010	010
	WATER COOLED	1	476-0745	644	644	644	644
43	GREASE SEAL	1	712-0231	653	653	653	653
	OIL SEAL	1	712-0016	653	653	653	653
44	GASKET	1	364-1309	614	614	614	614
45	CARTRIDGE	1	176-0065	010	010	010	010
46	GREASE SEAL	1	712-6324	653	653	653	653
	OIL SEAL	1	712-0053	653	653	653	653
47	BEARING	1	068-1907	647	647	647	647
48	SLINGER	1	764-1017	478	478	478	478
49	GLAND(SEAL)	2	372-0287	010	208	010	104
50	O-RING	2	364-0420	457	457	457	457

PC. NO.	DESCRIPTION	QTY	PART NO.	MATERIAL			
				B.F.	A.B.	A.I.	S.S.
52	LANTERN RING	2	676-1698	512	512	512	512
53	SEAL	2	712-0910	753	764	753	764
54	COLLAR	2	224-0174	208	208	010	104
55	SETSCREW	4	724-0081	104	104	104	104
56	BUSHING	2	136-1411	208	208	010	104
	SLEEVE WITH "O" RING PC. NO. 58 (NOTE 1)						
57	SLEEVE (PACKING)	1	756-0642	644	644	646	623
	SLEEVE (SEALS)	1	756-0642	644	644	623	623
58	O-RING	1	364-0368	457	457	457	457
59	IMPELLER						
	2x2-1/2x12A	1	443-2092	225	225	N/A	104
	2x2-1/2x12B	1	443-2127	225	225	N/A	104
	2x2x3x12A	1	443-2094	225	225	101	104
59	IMPELLER 9" & SMALLER & ALL 3500 RPM						
	2x2-1/2x12A	1	443-1127	225	225	N/A	104
	2-1/2x3x12A	1	443-1131	225	225	010	104
	IMPELLAR (MACHINED FOR OPT IMP RONG NO. 70). RING (OPT.)						
59	IMPELLER 9" & SMALLER & ALL 3500 RPM						
	2x2-1/2x12A	1	443-1897	225	225	N/A	104
	2x2-1/2x12B	1	443-2129	225	225	N/A	104
	2-1/2x3x12A	1	443-1899	225	225	010	104
60	IMPELLER 9" & SMALLER & ALL 3500 RPM						
	2x2-1/2x12A	1	443-1128	225	225	N/A	104
60	IMPELLER 9" & SMALLER & ALL 3500 RPM						
	2-1/2x3x12A	1	443-1132	225	225	010	104
60	O-RING	1	364-0368	457	457	457	457
61	BUSHING	1	136-1320	226	226	010	-
62	SEPARATOR SLEEVE WITH "O" RINGS PC NO 60 & 64 (NOTE 2)	1	756-0632	644	644	642	-
		1	592-0361	360	-	360	-
63	PIN	1	592-0051	-	235	-	235
64	O RING	1	364-0368	457	457	457	457
65	SLEEVE WITH "O" RING PC NO. 66 (NOTE 1)						
	SLEEVE (PACKING)	1	756-0642	644	644	646	623
	(SEALS)	1	756-0642	644	644	623	623
66	O RING	1	364-0368	457	457	457	457
67	IMPELLER						
	2x2-1/2x12A	1	443-2093	225	225	N/A	104
	2x2-1/2x12B	1	443-2128	225	225	N/A	104
	2-1/2x3x12A	1	443-2095	225	225	010	104
	9" DIA & SMALLER ALL 3500 RPM						
	2x2-1/2x12A	1	443-1125	225	225	N/A	104
	2-1/2x3x12A	1	443-1129	225	225	010	104
	IMPELLER MACHINED FOR OPT. IMP RING PC 70						
	2x2-1/2x12A	1	443-1898	225	225	N/A	104
	2x2-1/2x12B	1	443-2130	225	225	N/A	104
2-1/2x3x12A	1	443-190	225	225	010	104	
67	9" DIA & SMALLER ALL 3500 RPM						
	2x2-1/2x12A	1	443-1126	225	225	N/A	104
	2-1/2x3x12A	1	443-1130	225	225	010	104

Note 1) Material Code 644 - Sleeve 208, "O" Ring 457
 646 - Sleeve 108, "O" Ring 457
 623 - Sleeve 104, "O" Ring 457

420 SERIES P.S. #2. MODELS 421-422-423 2 X 2-1/2 X 12A&B - 2-1/2 X 3 X 12A PARTS LIST

PC. NO.	DESCRIPTION	QTY	PART NO.	MATERIAL				
				B.F.	A.B.	A.I.	S.S.	
68	KEY	1	472-0415	107	104	107	104	
69	PIN	2	592-0361	360	-	360	-	
		2	592-0051	-	235	-	235	
70	IMP RING (OPT)							
	2x2-1/2x12A	2	676-1056	208	208	-	104	
	2x2-1/2x12B	2	676-1014	208	208	-	104	
	2-1/2x3x12A	2	676-1014	208	208	010	104	
71	SHAFT	1	728-1040	063	104	063	104	
72	PIN	4	592-0213	104	104	104	104	
73	PIN	4	592-0213	104	104	104	104	
	CASING ASSY MODEL 421							
74	2x2-1/2x12A	1	179-1910	010	RTF	010	RTF	
	2x2-1/2x12B	1	179-1910	010	RTF	010	RTF	
	2-1/2x3x12A	1	179-1918	010	RTF	010	RTF	
	CASING ASSY MODEL 422 & 423							
	2x2-1/2x12A	1	179-1914	010	RTF	010	RTF	
75	2x2-1/2x12B	1	179-1914	010	RTF	010	RTF	
	2-1/2x3x12A	1	179-1922	010	RTF	010	RTF	
	DRIVE SCREW	2	708-0013	365	365	365	365	
76	NAMEPLATE	1	532-0045	114	114	114	114	
	NUT							
77	FR. 143HP-256HP	4	544-0109	080	190	080	104	
	FR. 284HP-445HP	4	544-0115	080	190	080	104	
	CAPSCREW							
78	FR. 143HP-256HP		168-0388	082	082	082	082	
	FR. 284HP-445HP		168-0566	082	082	082	082	
79	CAPSCREW	5	168-0490	082	082	082	104	
80	BRACKET		REFER TO FACTORY					
81	CAPSCREW	5	168-0490	082	082	082	104	
82	BASE		REFER TO FACTORY					

Note 1) Material Code 644 - Sleeve 208, "O" Ring 457/ 646 - Sleeve 108, "O" Ring 457/ 623 - Sleeve 104, "O" Ring 457

420 SERIES P.S. #3 MODELS 421-422-3 X 4 X 14A&B - 4 X 5 X 15 PARTS LIST

PC. NO.	DESCRIPTION	QTY	PART NO.	MATERIAL			
				B.F.	A.B.	A.I.	S.S.
1	PLUG MODEL 421	7	600-0003	087	190	087	104
	MODEL 422 & 423		REFER TO FACTORY				
2	PLUG	4	600-0002	087	190	087	104
6	CAPSCREW	16	168-0492	082	082	082	104
7	CAPSCREW	4	168-0492	082	082	082	104
8	CASING		INCLUDED WITH PC NO. 74				
	GASKET						
	3x4x14A&B	1	364-1226	598	598	598	598
9	BEFORE 3/78	1	364-1222	598	598	598	598
	4x5x15(421 ONLY)	1	364-1302	598	598	598	598
	BEFORE 3/78	1	364-1223	614	614	614	614
10	GREASE FITTING	2	508-0015	651	651	651	651
12	PLUG	2	600-0001	087	087	087	087
12A	PLUG*		600-0003	087	087	087	087
18	NUT	4	544-0109	-	190	080	104
19	WASHER	4	908-0112	-	190	080	104
20	CLAMP	4	204-0120	-	190	360	104
21	GLAND (PACKING)	2	372-0226	010	208	010	104
22	SWING BOLT	4	100-2011	-	190	104	104
22A	SWING BOLT ASSY (18,19,20,22)	4	099-0014	644	-	-	-
23	PACKING	12	564-0175	802	802	802	802
24	KEY	1	472-0318	087	087	087	087
25	CAPSCREW	4	168-0494	082	082	082	082
26	BEARING CAP	2	163-0307	010	-	010	-
27	PIN	2	592-0361	360	107	360	107
	CASE RING						
28	3x4x14A&B	2	676-1009	208	208	010	107
	4x5x15(421 ONLY)	2	676-1013	360	208	010	107
29	PROTECTOR	1	624-0081	087	087	087	087
31	CAPSCREW(STD)	4	168-0260	082	082	082	082
	WATER COOL(OPT)	4	168-0051	082	082	082	082
32	CARTRIDGE CAP(STD)	1	164-0550	010	010	010	010
	WATER COOLED	1	164-0088	326	326	326	326
34	GASKET	1	364-1310	614	614	614	614
35	RETAINING RING	1	676-0930	088	088	088	088
36	CARTRIDGE	1	176-0066	010	010	010	010
37	GREASE SEAL	1	712-6326	653	653	653	653
	OIL SEAL	1	712-0017	653	653	653	653

PC. NO.	DESCRIPTION	QTY	PART NO.	MATERIAL			
				B.F.	A.B.	A.I.	S.S.
38	BEARING	1	068-0455	647	647	647	647
39	SLINGER	1	764-1020	478	478	478	478
41	CAPSCREW(STD)	4	168-0260	082	082	082	082
	WATER COOL(OPT)	4	168-0051	082	082	082	082
42	CARTRIDGE CAP(STD)	1	164-0550	010	010	010	010
	WATER COOLED	1	164-0088	326	326	326	326
43	GREASE SEAL	1	712-6325	653	653	653	653
	OIL SEAL	1	712-0019	653	653	653	653
44	GASKET	1	364-1310	614	614	614	614
45	CARTRIDGE	1	176-0066	010	010	010	010
46	GREASE SEAL	1	712-6326	653	653	653	653
	OIL SEAL	1	712-0017	653	653	653	653
47	BEARING	1	068-1908	647	647	647	647
48	SLINGER	1	764-1020	478	478	478	478
49	GLAND(SEAL)	2	372-0289	010	208	010	104
50	O RING	2	364-0423	457	457	457	457
52	LANTERN RING	1	676-1899	512	512	512	512
53	SEAL	2	712-1012	753	764	753	764
54	COLLAR	2	224-0175	208	208	010	104
55	SETSCREW	4	724-0081	104	104	104	104
56	BUSHING	2	136-1412	208	208	010	104
	SLEEVE WITH "O" RING PC 58(NOTE 1)						
57	SLEEVE (PACKING)	1	756-0643	644	644	646	623
	SLEEVE (SEAL)	1	756-0643	644	644	623	623
58	O RING	1	364-0372	457	457	457	457
	IMPELLER						
59	3x4x14A	1	443-2137	225	225	010	104
	3x4x14B	1	443-2096	225	225	010	104
	4x5x15(421 ONLY)	1	443-2098	208	208	010	104
	IMPELLER FITTED WITH OPT. IMPELLER RING PC 70						
	3x4x14A	1	443-2125	643	643	642	646
	3x4x14B	1	443-1901	643	643	642	646
	4x5x15(421 ONLY)	1	443-2535	643	643	642	646
60	O RING	1	364-0372	457	457	457	457
61	BUSHING	1	136-1321	226	226	010	104
62	SEPARATOR SLEEVE WITH "O" RINGS PC NO. 60 & 64 (NOTE 2)	1	756-0633	644	644	642	-
63	PIN	1	592-0361	360		360	
		1	592-0051		235		235

*USED WITH WATER COOLED CARTRIDGE CAPS ONLY

Note 1) Material Code 644 - Sleeve 208, "O" Ring 457
646 - Sleeve 108, "O" Ring 457
623 - Sleeve 104, "O" Ring 457

Note 2) Material Code 644 - SEP SLEEVE 215, "O" RING 457
642 - SEP SLEEVE 010, "O" RING 457

420 SERIES P.S. #3 MODELS 421-422-3 X 4 X 14A&B - 4 X 5 X 15 PARTS LIST

PC. NO.	DESCRIPTION	QTY	PART NO.	MATERIAL				
				B.F.	A.B.	A.I.	S.S.	
64	O RING	1	364-0372	457	457	457	457	
	SLEEVE WITH "O" RING PC 66 (NOTE 1)							
65	SLEEVE (PACKING)	1	756-0643	644	644	646	623	
	SLEEVE (SEAL)	1	756-0643	644	644	623	623	
66	O RING	1	364-0372	457	457	457	457	
	IMPELLER							
	3x4x14A	1	443-2138	225	225	010	104	
	3x4x14B	1	443-2097	225	225	010	104	
67	4x5x15 (421 ONLY)	1	443-2099	208	208	010	104	
	IMPELLER (FITTED WITH OPT. IMP. RING PC 70)							
	3x4x14A	1	443-2126	643	643	642	646	
	3x4x14B	1	443-1902	643	643	642	646	
	4x5x15 (421 ONLY)	1	443-2536	643	643	642	646	
68	KEY	1	472-0416	107	104	107	104	
69	PIN	2	592-0361	360	-	360	-	
		2	592-0051	-	235	-	235	
	IMP RING (OPT)							
70	3x4x14A&B	2	676-1010	208	208	010	104	
	4x5x15 (421 ONLY)	2	676-2069	208	208	010	104	
71	SHAFT	1	728-1041	063	104	063	104	
72	PIN	2	592-0375	360	107	360	107	
73	PIN		REFER TO PIECE NO. 7					
	CASING ASSEMBLY MODEL 421							
	3x4x14A	1	179-2276	010	RTF	010	RTF	
	3x4x14B	1	179-2276	010	RTF	010	RTF	
74	4x5x15 (421 ONLY)	1	179-2276	010	RTF	010	RTF	
	CASING ASSEMBLY MODEL 422 & 423							
	3x4x14A	1	179-2278	010	RTF	010	RTF	
	3x4x14B	1	179-2278	010	RTF	010	RTF	
75	DRIVE SCREW	2	708-0013	365	365	365	365	
76	NAMEPLATE	1	532-0045	114	114	114	114	
	NUT							
77	FR. 143HP-256HP	4	544-0109	080	190	080	104	
	FR. 284HP-445HP	4	544-0115	080	190	080	104	
	CAPSCREW							
78	FR. 143HP-256HP	4	168-0388	082	082	082	082	
	FR. 284HP-445HP	4	168-0570	082	082	082	082	
79	CAPSCREW	5	168-0562	082	082	082	082	
80	BRACKET		REFER TO FACTORY					
81	CAPSCREW	5	168-0562	082	082	082	082	
82	BASE		REFER TO FACTORY					

NOTE 1) MATERIAL CODE

644 - SLEEVE 208, "O" RING 457

646 - SLEEVE 108, "O" RING 457

623 - SLEEVE 104, "O" RING 457

420 SERIES P.S. #4 MODEL 4215 X 6 X 15 PARTS LIST

PC. NO.	DESCRIPTION	QTY	PART NO.	MATERIAL			
				B.F.	A.B.	A.I.	S.S.
1	PLUG	7	600-0004	028	190	028	104
2	PLUG	4	600-0002	087	190	087	104
6	CAPSCREW	11	168-0566	082	082	082	104
	CAPSCREW(OVER BY-PASS)	5	168-0564	082	082	082	104
7	CAPSCREW	4	168-0494	082	082	082	104
8	CASING	INCLUDED WITH NO. 74					
9	GASKET	1	364-1224	598	598	598	598
10	GREASE FITTING	2	508-0015	651	651	651	651
12	PLUG	2	600-0001	087	087	087	087
12A	PLUG*	6	600-0003	087	087	087	087
18	NUT	4	544-0109	-	190	080	104
19	WASHER	4	908-0112	-	190	080	104
20	CLAMP	4	204-0120	-	190	360	104
21	GLAND(PACKING)	2	372-0227	010	208	010	104
22	SWING BOLT	4	100-2011	-	190	104	104
22A	SWING BOLT ASSY (18, 19, 20, 22).	4	099-0014	644	-	-	-
23	PACKING	12	564-0176	802	802	802	802
24	KEY	1	472-0318	087	087	087	087
25	CAPSCREW	4	168-0568	082	082	082	082
26	BEARING CAP	2	163-0308	010	-	010	-
27	PIN	2	592-0361	360	107	360	107
28	CASE RING	2	676-1012	208	208	010	107
29	PROTECTOR	1	624-0081	087	087	087	087
31	CAPSCREW(STD)	4	168-0260	082	082	082	082
	WATER COOL(OPT)	4	168-0049	082	082	082	082
CARTRIDGE CAP							
32	STANDARD	1	164-0532	010	010	010	010
	WATER COOLED		164-0087	326	326	326	326
34	GASKET	1	364-1311	614	614	614	614
35	RETAINING RING	1	676-0935	088	088	088	088
36	CARTRIDGE	1	176-0067	010	010	010	010
37	GREASE SEAL	1	712-6327	653	653	653	653
	OIL SEAL	1	712-0018	653	653	653	653
38	BEARING	1	068-0456	647	647	647	647
39	SLINGER	1	764-1022	478	478	478	478
41	CAPSCREW(STD)	4	168-0260	082	082	082	082
	WATER COOL(OPT)	4	168-0049	082	082	082	082
CARTRIDGE CAP							
42	STANDARD	1	164-0532	010	010	010	010
	WATER COOLED	1	164-0087	326	326	326	326
43	GREASE SEAL	1	712-6326	653	653	653	653
	OIL SEAL	1	712-0017	653	653	653	653
44	GASKET	1	364-1311	614	614	614	614
45	CARTRIDGE	1	176-0067	010	010	010	010

*USED WITH WATER COOLED CARTRIDGE CAPS ONLY

PC. NO.	DESCRIPTION	QTY	PART NO.	MATERIAL			
				B.F.	A.B.	A.I.	S.S.
46	GREASE SEAL	1	712-6327	653	653	653	653
	OIL SEAL	1	712-0018	653	653	653	653
47	BEARING	1	068-1909	647	647	647	647
48	SLINGER	1	764-1022	478	478	478	478
49	GLAND(SEAL)	2	372-0291	010	208	010	104
50	O RING	2	364-0425	457	457	457	457
52	LANTERN RING	1	676-1700	512	512	512	512
53	SEAL	2	712-1014	753	764	753	764
54	COLLAR	2	224-0176	208	208	010	104
55	SETSCREW	4	724-0081	104	104	104	104
56	BUSHING	2	136-1413	208	208	010	104
SLEEVE WITH "O" RING PC. 58(NOTE 1)							
57	SLEEVE(PACKING)	1	756-0644	644	644	646	623
	SLEEVE(SEAL)	1	756-0644	644	644	623	623
58	O-RING	1	364-0375	457	457	457	457
59	IMPELLER	1	443-2100	208	208	010	104
	IMPELLER(FITTED W/ OPT. IMP. RING NO. 70)	1	443-1905	643	643	642	646
60	O RING	1	364-0375	457	457	457	457
61	BUSHING	1	136-1322	226	226	010	104
SEPARATOR SLEEVE WITH "O" RINGS PC 60 & 64							
62	(NOTE 2)	1	756-0634	644	644	642	-
		1	592-0361	360	-	360	-
63	PIN	1	592-0051	-	235	-	235
		1	364-0375	457	457	457	457
64	O RING	1	364-0375	457	457	457	457
65 SLEEVE WITH "O" RING PC. 66(NOTE 1)							
	SLEEVE(PACKING)	1	756-0644	644	644	646	623
	SLEEVE(SEAL)	1	756-0644	644	644	623	623
66	O RING	1	364-0375	457	457	457	457
	IMPELLER	1	443-2101	208	208	010	104
	IMPELLER(FITTED W/ OPT. IMP RING PC 70)	1	443-1906	643	643	642	646
68	KEY	1	472-0417	107	104	107	104
69	PIN	2	592-0361	360	-	360	-
		2	592-0051	-	235	-	235
70	IMP RING(OPT)	2	676-1011	208	208	010	104
71	SHAFT	1	728-1042	063	104	063	104
72	PIN	2	592-0375	360	107	360	107
73	PIN	REFER TO PIECE NO. 7					
74	CASING ASSEMBLY	1	179-1938	010	RTF	010	RTF
75	DRIVE SCREW	2	708-0013	365	365	365	365
76	NAMEPLATE	1	532-0045	114	114	114	114

*USED WITH WATER COOLED CARTRIDGE CAPS ONLY

Note 1)Material Code 644 - Sleeve 208, "O" Ring 457
646 - Sleeve 108, "O" Ring 457
623 - Sleeve 104, "O" Ring 457

Note 2)Material Code 644 - SEP SLEEVE 215, "O" RING 457
642 - SEP SLEEVE 010, "O" RING 457

420 SERIES P.S.#5 MODEL 4216 X 8 X 17A&B PARTS LIST

PC. NO.	DESCRIPTION	QTY	PART NO.	MATERIAL			
				B.F.	A.B.	A.I.	S.S.
1	PLUG	7	600-0004	028	190	028	104
2	PLUG	4	600-0002	087	190	087	104
6	CAPSCREW	11	168-0636	082	082	082	104
7	CAPSCREW	4	168-0498	082	082	082	104
8	CASING	INCLUDED WITH NO. 74					
9	GASKET	1	364-1332	598	598	598	598
9	GASKET (BEFORE 3/78)	1	364-1225	614	614	614	614
10	GREASE FITTING	2	508-0015	651	651	651	651
12	PLUG	2	600-0001	087	087	087	087
12A	PLUG*	6	600-0003	087	087	087	087
18	NUT	4	544-0113	-	190	080	104
19	WASHER	4	908-0114	-	190	080	104
20	CLAMP	4	204-0121	-	190	360	104
21	GLAND (PACKING)	2	372-0228	010	208	010	104
22	SWING BOLT	4	100-2012	-	190	104	104
22A	SWING BOLT ASSY (18, 19, 20, 22)	4	099-0015	644	-	-	-
23	PACKING	12	564-0177	802	802	802	802
24	KEY	1	472-0321	087	087	087	087
25	CAPSCREW	4	168-0638	082	082	082	082
26	BEARING CAP	2	163-0309	010	-	010	-
27	PIN	2	592-0361	360	107	360	107
28	CASE RING	2	676-1750	208	208	010	107
29	PROTECTOR	1	624-0110	087	087	087	087
31	CAPSCREW (STD)	4	168-0260	082	082	082	082
	WATER COOL (OPT)	4	168-0047	082	082	082	082
32	CARTRIDGE CAP						
	STANDARD	1	164-0533	010	010	010	010
	WATER COOLED	1	164-0086	326	326	326	326
34	GASKET	1	364-1312	614	614	614	614
35	RETAINING RING	1	676-0943	088	088	088	088
36	CARTRIDGE	1	176-0068	010	010	010	010
37	GREASE SEAL	1	712-6329	653	653	653	653
	OIL SEAL	1	712-0037	653	653	653	653
38	BEARING	1	068-0458	647	647	647	647
39	SLINGER	1	764-1028	478	478	478	478
41	CAPSCREW (STD)	4	168-0260	082	082	082	082
	WATER COOL (OPT)	4	168-0047	082	082	082	082
	CARTRIDGE CAP						
42	STANDARD	1	164-0533	010	010	010	010
	WATER COOLED	1	164-0086	326	326	326	326
43	GREASE SEAL	1	712-6328	653	653	653	653
	OIL SEAL	1	712-0055	653	653	653	653
44	GASKET	1	364-1312	614	614	614	614
45	CARTRIDGE	1	176-0068	010	010	010	010
46	GREASE SEAL	1	712-6329	653	653	653	653
	OIL SEAL	1	712-0037	653	653	653	653
47	BEARING	1	068-0160	647	647	647	647
48	SLINGER	1	764-1028	478	478	478	478
49	GLAND (SEAL)	2	372-0293	010	208	010	104
50	O RING	2	364-0429	457	457	457	457
52	LANTERN RING	1	676-1701	512	512	512	512
53	SEAL	2	712-1017	753	764	753	764

*USED WITH WATER COOLED CARTRIDGE CAPS ONLY

PC. NO.	DESCRIPTION	QTY	PART NO.	MATERIAL			
				B.F.	A.B.	A.I.	S.S.
54	COLLAR	2	224-0177	208	208	010	104
55	SETSCREW	4	724-0081	104	104	104	104
56	BUSHING	2	136-1414	208	208	010	104
	SLEEVE WITH "O" RING PC 58 (NOTE 1)						
57	SLEEVE (PACKING)	1	756-0645	644	644	646	623
	SLEEVE (SEAL)	1	756-0645	644	644	623	623
58	O-RING	1	364-0380	457	457	457	457
	IMPELLER						
	6x8x17A	1	443-2133	208	208	010	104
59	6x8x17B	1	443-2102	208	208	010	104
	IMPELLER (FITTED WITH/OPT IMP RING 70)						
	6x8x17A	1	443-2131	643	643	642	646
	6x8x17B	1	443-2135	643	643	642	646
60	O RING	1	364-0380	457	457	457	457
61	BUSHING	1	136-1323	226	226	010	104
62	SEPARATOR SLEEVE WITH "O" RING PC 60 & 64 (NOTE 2)						
		1	756-0635	644	644	642	-
63	PIN	1	592-0361	360	-	360	-
		1	592-0051	-	235	-	235
64	O RING	1	364-0380	457	457	457	457
	SLEEVE WITH "O" RING PC 66 (NOTE 1)						
	(PACKING)	1	756-0645	644	644	646	623
	(SEAL)	1	756-0645	644	644	623	623
66	O RING	1	364-0380	457	457	457	457
	IMPELLER						
	6x8x17A	1	443-2134	208	208	010	104
67	6x8x17B	1	443-2103	208	208	010	104
	IMPELLER (FITTED W/OPT. IMP RING NO. 70)						
	6x8x17A	1	443-2132	643	643	642	646
	6x8x17B	1	443-2136	643	643	642	646
68	KEY	1	472-0418	107	104	107	104
69	PIN	2	592-0361	360	-	360	-
		2	592-0051	-	235	-	235
70	IMP RING (OPT)	2	676-1054	208	208	010	104
71	SHAFT	1	728-1043	063	104	063	104
72	PIN	2	592-0375	360	107	360	107
73	PIN	REFER TO PIECE NO. 7					
74	CASE ASSY	1	179-2266	010	RTF	010	RTF
75	DRIVE SCREW	2	708-0013	365	365	365	365
76	NAMEPLATE	1	532-0045	114	114	114	114
83	SETSCREW	6	724-0027	104	104	104	104

*USED WITH WATER COOLED CARTRIDGE CAPS ONLY

Note 1) Material Code 644 - Sleeve 208, "O" Ring 457
646 - Sleeve 108, "O" Ring 457
623 - Sleeve 104, "O" Ring 457

Note 2) Material Code 644 - SEP SLEEVE 215, "O" RING 457
642 - SEP SLEEVE 010, "O" RING 457

STANDARD LIMITED WARRANTY

Seller warrants equipment (and its component parts) of its own manufacture against defects in materials and workmanship under normal use and service for one (1) year from the date of installation or start-up, or for eighteen (18) months after the date of shipment, whichever occurs first. Seller does not warrant accessories or components that are not manufactured by Seller; however, to the extent possible, Seller agrees to assign to Buyer its rights under the original manufacturer's warranty, without recourse to Seller. Buyer must give Seller notice in writing of any alleged defect covered by this warranty (together with all identifying details, including the serial number, the type of equipment, and the date of purchase) within thirty (30) days of the discovery of such defect during the warranty period. No claim made more than 30 days after the expiration of the warranty period shall be valid. Guarantees of performance and warranties are based on the use of original equipment manufactured (OEM) replacement parts. Seller assumes no responsibility or liability if alterations, non-authorized design modifications and/or non-OEM replacement parts are incorporated. If requested by Seller, any equipment (or its component parts) must be promptly returned to Seller prior to any attempted repair, or sent to an authorized service station designated by Seller, and Buyer shall prepay all shipping expenses. Seller shall not be liable for any loss or damage to goods in transit, nor will any warranty claim be valid unless the returned goods are received intact and undamaged as a result of shipment. Repaired or replaced material returned to customer will be shipped F.O.B., Seller's factory. Seller will not give Buyer credit for parts or equipment returned to Seller, and will not accept delivery of any such parts or equipment, unless Buyer has obtained Seller's approval in writing. The warranty extends to repaired or replaced parts of Seller's manufacture for ninety (90) days or for the remainder of the original warranty period applicable to the equipment or parts being repaired or replaced, whichever is greater. This warranty applies to the repaired or replaced part and is not extended to the product or any other component of the product being repaired. Repair parts of its own manufacture sold after the original warranty period are warranted for a period of one (1) year from shipment against defects in materials and workmanship under normal use and service. This warranty applies to the replacement part only and is not extended to the product or any other component of the product being repaired. Seller may substitute new equipment or improve part(s) of any equipment judged defective without further liability. All repairs or services performed by Seller, which are not covered by this warranty, will be charged in accordance with Seller's standard prices then in effect.

THIS WARRANTY IS THE SOLE WARRANTY OF SELLER AND SELLER HEREBY EXPRESSLY DISCLAIMS AND BUYER WAIVES ALL OTHER WARRANTIES EXPRESSED, IMPLIED IN LAW OR IMPLIED IN FACT, INCLUDING ANY WARRANTIES OF MERCHANTABILITY OR FITNESS FOR A PARTICULAR PURPOSE. Seller's sole obligation under this warranty shall be, at its option, to repair or replace any equipment (or its component parts) which has a defect covered by this warranty, or to refund the purchase price of such equipment or part. Under the terms of this warranty, Seller shall not be liable for (a) consequential, collateral, special or liquidated losses or damages; (b) equipment conditions caused by normal wear and tear, abnormal conditions of use, accident, neglect, or misuse of said equipment; (c) the expense of, and loss or damage caused by, repairs or alterations made by anyone other than the Seller; (d) damage caused by abrasive materials, chemicals, scale deposits, corrosion, lightning, improper voltage, mishandling, or other similar conditions; (e) any loss, damage, or expense relating to or resulting from installation, removal or reinstallation of equipment; (f) any labor costs or charges incurred in repairing or replacing defective equipment or parts, including the cost of reinstalling parts that are repaired or replaced by Seller; (g) any expense of shipment of equipment or repaired or replacement parts; or (h) any other loss, damage or expense of any nature.

The above warranty shall not apply to any equipment which may be separately covered by any alternate or special warranties.

PERFORMANCE: In the absence of Certified Pump Performance Tests, equipment performance is not warranted or guaranteed. Performance curves and other information submitted to Buyer are approximate and no warranty or guarantee shall be deemed to arise as a result of such submittal. All testing shall be done in accordance with Seller's standard policy under Hydraulic Institute procedures.

LIABILITY LIMITATIONS: Under no circumstances shall the Seller have any liability under the Order or otherwise for liquidated damages or for collateral, consequential or special damages or for loss of profits, or for actual losses or for loss of production or progress of construction, regardless of the cause of such damages or losses. In any event, Seller's aggregate total liability under the Order or otherwise shall not exceed the contract price.

ACTS OF GOD: Seller shall in no event be liable for delays in delivery of the equipment or other failures to perform caused by fires, acts of God, strikes, labor difficulties, acts of governmental or military authorities, delays in transportation or procuring materials, or causes of any kind beyond Seller's control.

COMPLIANCE WITH LAW: Seller agrees to comply with all United States laws and regulations applicable to the manufacturing of the subject equipment. Such compliance shall include: The Fair Labor Standards Acts of 1938, as amended; Equal Employment Opportunity clauses of Executive Order 11246, as amended; Occupational Safety and Health Act of 1970 and the standards promulgated thereunder, if applicable. Since compliance with the various Federal, State, and Local laws and regulations concerning occupational health and safety, pollution or local codes are affected by the use, installation and operation of the equipment and other matters over which Seller has no control, Seller assumes no responsibility for compliance with those laws and regulations, whether by way of indemnity, warranty, or otherwise. It is incumbent upon the Buyer to specify equipment which complies with local codes and ordinances.



800 Airport Road | North Aurora, Illinois 60542 | Ph: 630.859.7000 | pentair.com

Pentair trademarks and logos are owned by Pentair or its affiliates. Third party registered and unregistered trademarks and logos are the property of their respective owners. Because we are continuously improving our products and services, Pentair reserves the right to change specifications without prior notice. Pentair is an equal opportunity employer.

A-03-227 (06-15-22) ©2022 Pentair. All Rights Reserved.