

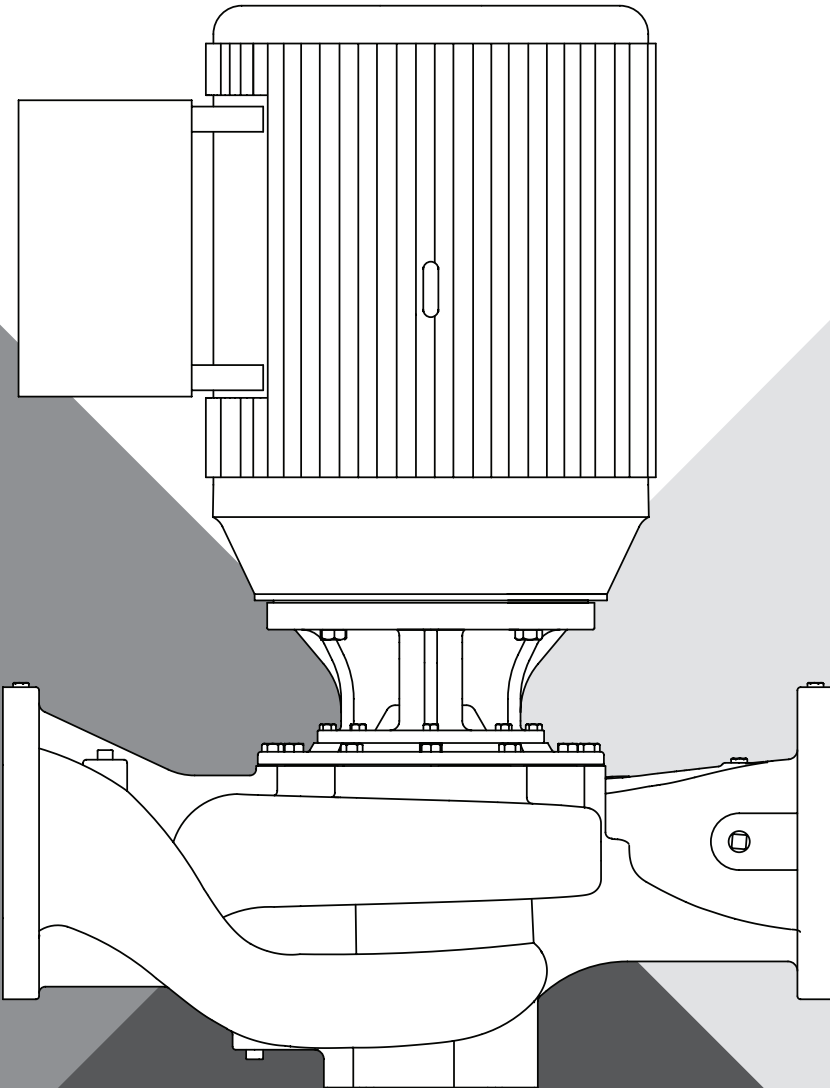

VERTICAL IN-LINE CLOSE COUPLED PUMPS
SERIES 382B CC



INSTALLATION AND
OPERATION MANUAL

pentair.com

TABLE OF CONTENTS:

SECTION.....	PAGE
General Information.....	3
Transport and Storage.....	4
Product Description	5
Pump Installation.....	6
Pump Operation.....	7-8
Pump Maintenance and Service	9-12
Troubleshooting Guide.....	13-14
Assembly Exploded View	15
Part List.....	16
Standard Limited Warranty	17

GENERAL INFORMATION

NOTICE to the installer: Please make sure you provide this manual to the owner of the equipment or to the responsible party who maintains the system.

This manual contains important information for the safe use of Pentair Aurora* 382B Vertical In-line Close Coupled Pumps. Read this manual completely before using this product. **DO NOT DISCARD OR LOSE THIS MANUAL.**

Pentair Aurora 382B Close Coupled (CC) series pumps are superior commercial in-line pumps which have been manufactured and field tested under the severest demands. Pumping applications for the Pentair Aurora 382B CC include: hot or chilled water circulation, pressure booster systems and cooling towers for office buildings, hotels, hospitals, universities and warehouses.

SAFETY

Explanation of Designations

▲ DANGER warns about hazards that will cause serious personal injury, death or major property damage if ignored.

▲ WARNING warns about hazards that can cause serious personal injury, death or major property damage if ignored.

▲ CAUTION warns about hazards that will or can cause minor personal injury or property damage if ignored.

NOTICE: indicates special instructions which are important but not related to hazards.

General Guidelines

- These instructions must always be kept close to the product's operating location or directly with the product.
- These instructions should be read prior to installing, operating, using and maintaining the equipment in any region worldwide. The equipment must not be put into service until all the conditions relating to safety, noted in the instructions, have been met.
- The product must not be operated beyond the parameters specified for the application. If there is any doubt as to the suitability of the product for the application intended, contact Pentair Aurora Customer Service for advice, quoting the serial number.

Personnel Qualification and Training

All personnel involved in the operation, installation, inspection and maintenance of the unit must be qualified to carry out the work involved. If the personnel in question do not already possess the necessary knowledge and skill, appropriate training and instruction must be provided.

It is recommended that proper documentation of personnel should be maintained by the responsible part(ies).

Personnel Safety Actions

CALIFORNIA PROPOSITION 65 WARNING:

▲ WARNING This product and related accessories contain chemicals known to the State of California to cause cancer, birth defects or other reproductive harm.

▲ DANGER Never do maintenance work when the unit is connected to power. Always follow lock out – tag out procedures when working on equipment that may turn on.

▲ WARNING Guards must not be removed while the pump is operational. Always follow lock out – tag out procedures when working on equipment that may turn on.

▲ WARNING Drain the pump and isolate pipe work before dismantling the pump. The appropriate safety precautions should be taken where the pumped liquids are hazardous.

▲ WARNING Handling components: Many precision parts have sharp corners, thus wearing of appropriate safety gloves and equipment is required when handling these components. To lift heavy pieces above 25 kg (55 lb.) use a crane appropriate for the mass and in accordance with current local regulations.

▲ WARNING Thermal shock: Rapid changes in the temperature of the liquid within the pump can cause thermal shock, which can result in damage or breakage of components and should be avoided.

▲ WARNING Never apply heat to remove impeller.

▲ WARNING Noise & vibration levels: Pentair Aurora 382B CC pumps have been designed to meet the noise and vibration levels as per the Hydraulic Institute (HI) standard 9.6.4.

Electrical Safety

▲ WARNING Sudden start-up hazard: Disconnect and lock out power source before servicing. Failure to follow these instructions could result in serious personal injury, death or property damage.

▲ WARNING Electrical shock hazard: All electrical connections are to be made by a qualified electrician in accordance with all codes and ordinances. Failure to follow these instructions could result in serious personal injury, death or property damage.

▲ WARNING Electrical overload hazard: Ensure all motors have properly sized overload protection. Failure to follow these instructions could result in serious personal injury, death or property damage.

High Temperature Safety

▲ WARNING Hot surface hazard: If pumping hot water, ensure guards or proper insulation is installed to protect against skin contact with hot piping or pump components. Failure to follow these instructions could result in serious personal injury, death or property damage.

▲ WARNING Spraying water hazard: When servicing pump, replace all gaskets and seals. Do not reuse old gaskets or seals. Failure to follow these instructions could result in serious personal injury, death or property damage.

High Pressure Safety

▲ WARNING High pressure hazard: All pumps are designed for specific maximum working pressure. Do not exceed this pressure. Install properly sized pressure relief valves in system. Failure to follow these instructions could result in serious personal injury, death or property damage.

▲ WARNING Expansion hazard: Water expands when heated. Install properly sized thermal expansion tanks and relief valves. Failure to follow these instructions could result in serious personal injury, death or property damage.

TRANSPORT AND STORAGE

CAUTION

- Ensure correct lubrication.
- Start the pump at reduced speed or with the discharge valve partly opened (unless otherwise instructed at a specific point in the user instructions). This is recommended to minimize the risk of overloading and damaging the pump motor at full or zero flow. Pumps may be started with the valve further open only on installations where this situation cannot occur. The pump discharge control valve may need to be adjusted to comply with the duty following the run-up process. (See "Pump Operation" on Page 7.)
- Suction valves to be fully open when pump is running. Running the pump at a flow rate below the manufacturer's recommended minimum flow rate will cause damage.
- Do not run the pump continuously outside the allowable operating region. Operating at a flow rate higher than normal or at a flow rate with no backpressure on the pump may overload the motor and cause cavitation. Low flow rates may cause a reduction in pump/bearing life, overheating of the pump, instability, and cavitation/vibration.
- Handling, transportation and installation of this equipment should only be undertaken by qualified personnel with proper use of lifting equipment.
- Only water or other suitable HVAC media may be circulated through the use of these pumps. Circulation of hazardous, corrosive or flammable liquids by using these pumps is strictly prohibited.
- DO NOT turn on the electrical supply to the pump until all the plumbing connections and commissioning procedure have been accomplished.
- The pump must not be operated dry without fluid.
- Pipe systems must be installed in such a manner so that no load is transferred on pump flanges.
- Ensure that the motor installation instruction manual has been followed for determining the proper terminal connections so that correct pump rotation is obtained.

TRANSPORT AND STORAGE

Transport and Handling Requirements

The pump has been prepared for shipment at the factory in such a way as to minimize potential damage due to handling and transport. The equipment should not be subjected to excessive G-forces during the handling or transport. For large, heavy, rotating components, the manufacturer shall consider and adapt a means to restrict the movement of the rotating assembly to prevent damage to the bearings during transport. All such means should be removed before installation.

Uncrating and Lifting

Pump is fastened securely to the crate before shipment. The pump should be removed from the crate carefully by using proper tools and equipment. After removing from crate make sure that all the components are in good condition and have been received as mentioned in the packing list.

Report immediately to the concerned person/department if any component is missing or received in a damaged condition. Extreme care must be taken while handling the pump set. Slings and hooks should be used in such a manner, so that while lifting, the pump is not exposed to stresses.

While lifting the pump or pump set (with or without driver) suitable lifting equipment of adequate capacity should be used. The unit should be unloaded and handled by lifting equally. Entire pump should be lifted at

four or more points provided in base frame. Attach nylon slings, chains, or wire rope to the hooks or clevises for lifting. Ensure that the lift angle of the slings, chains or wire rope is less than 45° from vertical.

Methodology to Orient Pumps Vertically While Unpacking the Unit

Since the pumps are shipped horizontally laid on crate, it is necessary to orient pumps vertically before shifting to their installation location. Once the unit is uncovered, lift the unit by placing straps around the motor while making a pivot point of casing. Human effort will also be required to orient the unit to vertical position. Now let the unit to rest on crate and follow the procedure mentioned below to place the unit to its desired location.

NOTICE: For typical installation, suitable overhead lifting equipment of adequate capacity to lift the driver, the entire pump (without driver), or the heaviest sub assembly of the pump should be available at the jobsite when installing or removing the pump.

Use Following Procedure for Lifting the Pump Set.

1. Place lifting straps/slides on each side of shaft through the motor bracket as shown in Figure 1 below.

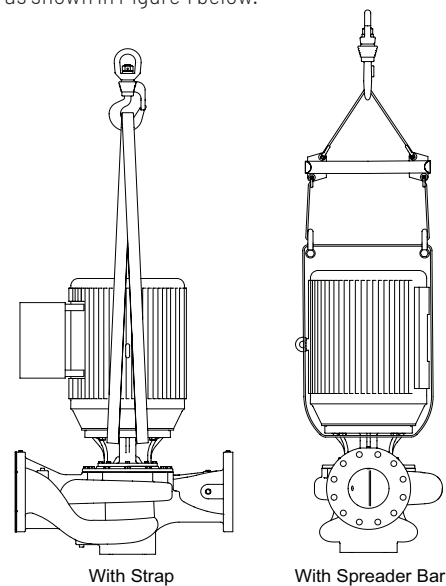

Figure 1

2. Use spreader bar (see Figure 1 shown above) in between the slings if necessary. This could be helpful for protecting the motor fan cover while lifting.
3. DO NOT use eye bolt or lifting lugs on motor and/or motor bracket for lifting the entire unit.
4. DO NOT place cable slings around the motor shaft.

PRODUCT DESCRIPTION

Receipt, Inspection, and Damage Reporting

Upon receipt of the pump, immediately check for shortages of parts and damages. Prompt reporting to the carrier's agent, with notations made on the freight bill, may expedite satisfactory adjustment by the carrier.

This should be done at once. Do not unpack any more than required to verify that the equipment is complete and undamaged unless installation is to be done immediately. Do not leave the pump unit or any accessories exposed to weather or construction hazards, which may cause damage to the equipment.

Unpacking

As stated above, do not unpack any more than required to verify that the equipment is complete and undamaged unless installation is to be done immediately. Check all packing material that is to be discarded to verify that no parts or instructions are being accidentally discarded as well. It is recommended to leave small parts in their shipping container until installation so they are not misplaced. Make certain that accessories with a pump unit are clearly marked showing which pump unit they are to be used with. Clean all parts of all dirt, packing materials, and other foreign matter. Clean all non-coated machined surfaces. If the pump is to be installed immediately, then clean all coated machined surfaces too. Remove any rust spots found on the machined surfaces with a fine emery cloth. Clean all threaded connections and any accessory equipment.

Storage

The standard packaging is suitable for protection during shipment and during covered storage at the jobsite for a short period between installation and start-up. The preservatives applied at the factory have an effective life of two to three months from date of shipment, depending on the severity of the environment in which the equipment is stored.

Short-Term Storage

The pump and equipment, as shipped, have adequate protection for short-term (up to three months) storage in a covered, dry, and ventilated location at the jobsite prior to installation.

- Dry pump internals and spray the liquid end with a water-displacement rust inhibitor.
- Apply a film of compatible lube oil over the water-displacement rust preventative. After the pump has been thoroughly drained, cover the pump suction and discharge flanges with full gasket material and blank off these openings with metal blank flanges and a minimum of four bolts. Cover the pump stuffing box opening with a non-hygroscopic tape. If mechanical seals have been used, then the annular opening between gland plate and shaft should be closed by a removable sealing ring supplied by the original equipment manufacturer to exclude airborne dust. Additionally, all connections in the seal cartridge must be plugged or sealed.
- All exposed painted surfaces should be dry, clean, and free of grease and other contaminants.
- The pump should be covered with a weather-resistant material, such as waterproof paper or plastic, to prohibit the buildup of dirt and dust accumulations.

Long-Term Storage

All pumps are factory serviced and delivered in a ready to operate condition. If after being delivered the pump is not put into immediate operation then proper care should be taken so that it operates without failure when put into service. The pump should be kept in a clean and dry area in a vertical position. Ensure that the following precautions are taken for pumps being stored for more than six months:

- Pump surfaces which are machined and unpainted (e.g. flange ends, feet mounting, etc.) and are easily subjected to corrosion must be protected by corrosion resistant coating.
- The pump shaft should be rotated once per month to avoid locking of rotating assembly. This would also be helpful in uniform distribution of lubrication on bearings.
- Motor bearings, if regreaseable type, should be lubricated with fresh lubricants per motor manufacturers instructions when a pump is being put into service after a long time.

Disposal of Packaging Materials

Most of the materials supplied in the pump unit are suitable for recycling. Please conserve our natural resources and recycle these materials.

PRODUCT DESCRIPTION

Configuration

Pentair Aurora* 382B CC Pumps are offered with Type 21 mechanical seal with standard temperature and pressure limits.

Pumps are also offered with following options required and mentioned by customer at the time of placing order:

- With flush line
- With or without abrasive separator
- Base options

Parts

Refer to "Assembly Exploded View" Figure 17 on Page 15 for listing various parts.

PUMP INSTALLATION

INSTALLATION

Installation Configuration

The pump has been designed to be installed in various configurations as shown in the images below.

NOTICE: The installation conditions shown in below images are for representation purpose only. The parts, accessories and supporting arrangements are not supplied with the pump unit unless otherwise specified.

1. Hanger Supported Pipe Mounted

Where floor space is a restriction, Pentair Aurora* 382B CC Vertical In-line pumps can be installed in the system piping without any additional support from base, as illustrated in Figure 2 shown below. For such an installation, care must be taken to ensure that pipe hangers are designed to bear additional weight of pump set.

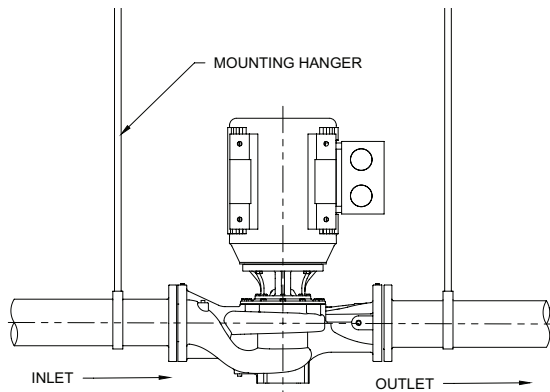

Figure 2

2. Pipe Mounted Supported at Ceiling

In tight rooms pump can be installed directly into the system piping with no base support and piping can be supported close to ceiling. With this arrangement the pump may be installed with a multi-purpose valve on the discharge side and suction diffuser on the suction side of the pump, as illustrated in Figure 3 shown below.

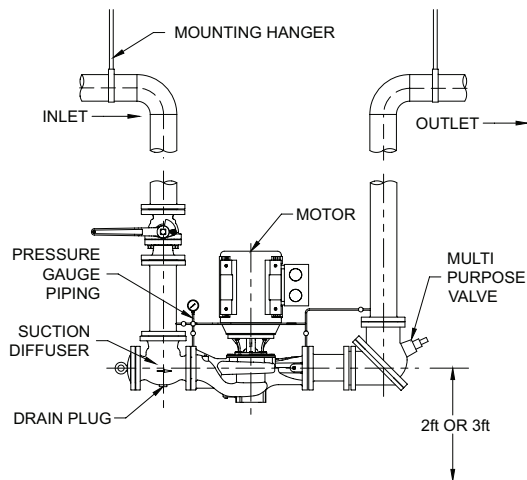

Figure 3

3. Floor Saddle Support

In many of the installation locations where support to pump from above is not possible, floor mounted saddle support can be provided beneath suction and discharge piping. The pump case may be mounted on a base in such an installation but is not necessary. The installation is illustrated in Figure 4 shown below.

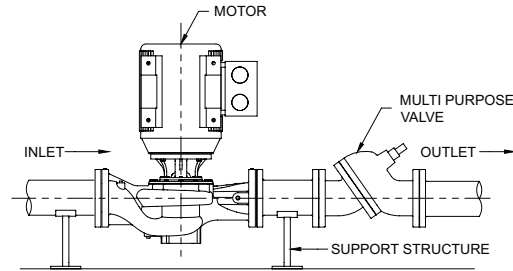

Figure 4

4. Pipe Supports

For ease of installation and increasing rigidity of the unit, a structural support may be provided at the pump suction and discharge ports with isolation pads beneath the support, as illustrated in Figure 5 shown below. Ensure that pipe hangers are adjusted so the pump flanges do not support the piping.

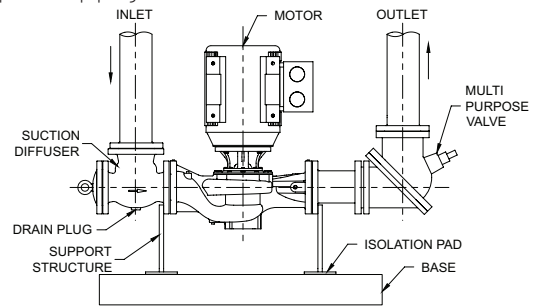

Figure 5

5. Floor Mounted

Make sure that pump is firmly bolted to the mounting base which in turn is also rigidly secured and mounted on the floor. During floor mounting it is recommended that flexible connectors are used to eliminate the potential for pipe load to be transferred to the pump. If flexible connectors are not used, it is very important to closely monitor the height of the pump support. If the height of support is more than required then the entire pipe load will be transferred to the pump which will start acting like a pipe support. See figures 6A and 6B shown below for reference.

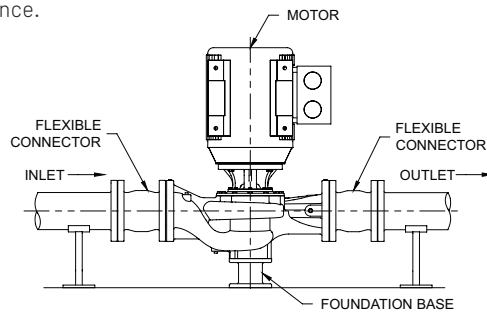

Figure 6A

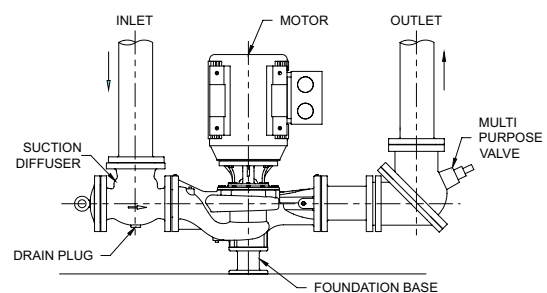

Figure 6B

PUMP OPERATION

When the pump is floor mounted, the piping will still need to be supported on both the suction and discharge sides to eliminate pipe stress at the pump. For supporting the pump from the bottom, case feet have been drilled and tapped to use commonly available pipe flanges to create the pump support. See Table 1 shown below for standard flange sizes for drilling.

Table 1

Pentair Aurora 382B – CC	Feet drilling as per Class 125 flange
1.5x1.5x7, 1.5x1.5x9.5	1.5"
2.5x2.5x7, 2x2x11, 2x2x7, 3x3x11A	2"
3x3x7	2.5"
2.5x2.5x9.5, 3x3x9.5, 4x4x7, 4x4x9.5	3"
3x3x13.5, 4x4x11, 4x4x13.5, 5x5x11A, 5x5x13.5, 5x5x7, 5x5x9.5, 6x6x13.5, 6x6x7, 6x6x9.5	4"
10x10x13.5, 6x6x11, 8x8x11A, 8x8x13.5, 8x8x9.5	6"

Pump Location

The pump should be located as close to the liquid source as possible so that the suction line can be short and direct. Location should require a minimum of elbows and fittings in the discharge line to minimize friction losses. The pump must be protected against flooding and located in a clean, open area, where it is easily accessible for inspection, disassembly and repair.

To minimize friction losses pump should be located such that the use of elbows and fittings in the discharge line is reduced. Pumps installed in dark, dirty areas or in cramped locations are often neglected, which can result in premature failure of both the pump and the driver. Open area would also be helpful in better air flow into the motor and/or motor fan.

Pentair Aurora* 382B CC pump must be installed vertically. For horizontal installation refer to factory. Install isolating valves on each side of pump so that pump maintenance can be performed without draining the system. Special mounting requirements may be required if the pump is to be mounted near a noise or vibration sensitive area. Change the boxed content to read:

The installation must be evaluated to ensure that the net positive suction head available (NPSHA) meets or exceeds the limits as stated below:

- 2 ft for building services
- 5 ft for municipal application

Seismic Analysis

Please consult factory if the pump is to be installed in seismic zones.

Piping and Connections

A minimum length of straight pipe is required on the suction side of the pump. Five times the pipe diameter is sufficient to allow a smooth entry of liquid into the pump.

Avoid using short elbows as they tend to give higher friction losses and interruption in streamline flow. Suction and discharge piping must be in line. To avoid undue stresses on pump and pipe flanges, never force align the pipes and provide a rigid support near the pump casing. Pump flanges must be tightened evenly to avoid flange cocking and liquid leakage.

Air leak/trapped in suction piping is one of the major causes of erratic pump performance. To avoid any such kind of trouble, suction piping should be arranged in such a manner that there are no high spots. This is to ensure that air is not trapped in the suction line which will cause faulty pump operation. Wherever suction line is larger than the pump suction nozzle, it is mandatory to use an eccentric reducer. For sumps below center line the straight side of the reducer must be located upwards so that any air cavity if present in the suction line passes through the line to outlet and there is no pressure drop at pump suction due to presence of air pockets.

The check valve must be installed in the discharge line which prevents backward flow of liquid into the pump, thereby protecting the pump from liquid back pressure.

NOTICE: The suction valve should be fully open and should not be used for flow regulation. The discharge valve is to be used for flow regulation.

Pipe Supports/Anchors/Joints

- Suction and discharge piping should be anchored, supported, and restrained near the pump to avoid application of forces and moments to the pump in excess of those permitted.
- Expansion joints or flexible connections provided at the pump suction and discharge may need to be restrained to prevent transmitting excessive loads to the pump.
- If it is necessary to use an expansion joint or non-rigid coupling, then it is recommended that a pipe anchor be located between it and the pump.

PUMP OPERATION

COMMISSIONING, START-UP, OPERATION, AND SHUTDOWN

COMMISSIONING

Lubrication

The pump does not contain any bearings that require lubrication; however motor bearings must be lubricated periodically

CAUTION Before running the driver, either separately or connected to the pump, check lubrication and cooling requirements.

Rotation

Before starting, check the direction of rotation. The direction is indicated by a direction arrow on the pump casing. The proper rotation can be easily determined by observing the direction of the casing scroll and the position of the discharge nozzle.

It is absolutely essential that the rotation of the motor be checked and because of the close-coupled design of the 382B CC pumps, this must be done by electrically "bumping" the motor very briefly to check rotation. Incorrect rotation of the pump, for even a short time, can dislodge and damage the impeller, casing, shaft, and shaft seal.

Guarding

All guards must be in place and secure per the manufacturer's instructions prior to start-up.

START-UP CONSIDERATIONS

System Flushing

When the pump is installed in the completed piping system, it is recommended that the system be flushed to remove debris such as stubs of welding rod, welding slag, and loose scale.

PUMP OPERATION

Priming and Filling

A pump is considered to be primed when the casing and the suction piping are completely filled with liquid. Open discharge valves a slight amount. This will allow any entrapped air to escape and will normally allow the pump to prime, if the suction source is above the pump. When a condition exists where the suction pressure may drop below the pump's capability, it is recommended to add a low-pressure control device to shut down the pump when the pressure drops below a predetermined minimum.

SHAFT SEALING SETTINGS AND ADJUSTMENTS

A mechanical seal consists of a rotating element and a stationary element. The sealing faces are highly lapped surfaces of materials selected for their low coefficient of friction and their resistance to corrosion by the liquid being pumped. The faces run with a very thin film of liquid between them. In addition, there must be a means of loading the seal. This is accomplished either with a spring (or springs) or with an elastomeric or metallic flexible member. Mechanical seals are made in a wide variety of designs; therefore the instructions for the specific seal must be carefully studied and followed. A mechanical seal is a precision device and must be treated accordingly. Mechanical seals normally require no adjustment during operation. Except for slight initial leakage, the seal should operate with negligible leakage.

CAUTION Mechanical seals should not run dry unless allowed by the manufacturer. Seals require a continuous supply of flush and/or cooling fluid.

OPERATION, START-UP, AND SHUTDOWN

Pump Operation

The following points must be ensured before starting the pump:

1. The current supply agrees with the voltage and frequency on the motor nameplate.
2. The motor is wired for correct voltage.
3. The thermal overload relays are correct size and set for operation.
4. The pump is fully primed. Flood the casing and seal area with liquid to release the air out of pump through flush line and air vent valve near discharge flange. Priming must be continued until air is completely removed. This would be indicated by continuous flow of liquid through flush line and air vent.

NOTICE: Failure to flood the seal area with water may cause seal failure due to lack of lubrication.

5. Jog the motor to check that the motor rotates clockwise, as indicated by the arrow on the pump casing.

Coupling guard must be in its appropriate position on account of human safety.

Starting Up

NOTICE: MAKE SURE SUCTION LINE VALVE IS IN OPEN POSITION AND DISCHARGE LINE VALVE IS CLOSED.

1. Check that the pump is operating smoothly and is not rubbing.
2. Start opening the discharge valve gradually.

NOTICE: Do not run the pump for extended period with discharge valve closed, so as to avoid overheating and potential damaging loads.

3. Stop the pump immediately if any of the following situations arise:
 - a. No/insufficient liquid.

- b. Inadequate discharge pressure.
- c. Loss of suction pressure.
- d. High power consumption.
- e. Noisy operation and/or high vibration.
Check the manual for troubleshooting the cause.

Shutdown

It is recommended to close the discharge valve before stopping the pump to avoid any water hammer effect. However, this practice is not mandatory and pump may be stopped with discharge valve open in case of an emergency.

Preferred shutdown sequence is as follows:

1. Preferably close the discharge valve first.
2. Then turn off the motor.
3. Now, close the suction line valve.
4. Drain the pump liquid completely, if pump to be kept nonoperational for longer period or if there is danger of freezing.

PUMP MAINTENANCE AND SERVICE

MAINTENANCE AND SERVICE

Schedule

Preventive maintenance and routine check-ups may prevent the pump from major failures. An inspection & maintenance log should be kept and the inspector should immediately report any problems. Pump should be checked on regular basis for any unusual noise, vibrations and abnormal rise of temperature. Also, check the sight flow indicator, if so equipped, from time to time for fluid flow and if no flow is observed, replace the filter or check the separator. A suggested guide for preventive maintenance for normal application is given below in Table 2.

Table 2

GUIDE FOR PREVENTIVE MAINTENANCE

Items	Action required	Frequency
Vibration	Check for change in vibration	Refer to ANSI/ISO 9.6.5 Condition Monitoring
Bolting	Check for loose bolting	Annually
Mechanical seals	Monitor seal leakage	Refer to ANSI/ISO 9.6.5 Condition Monitoring
Pump/Motor alignment	Check for change in alignment	Annually
Surface inspection	Check for coating integrity or signs of corrosion	Exterior components: Quarterly Interior components: Annually
Wear and running clearance	Inspect and measure	Annually or as determined by service condition when performance decreases are noted or as recommended
No flow in sight flow indicator (if installed)	Replace filter, Inspect separator	Daily
Controls and accessories	Inspect for damage, proper function and condition	Annually
General site conditions	Inspect for damage, proper function and condition	150 hours of operation as necessary

Cold Weather Maintenance

When handling water, care should be taken to prevent the pump from freezing during cold weather when the pump is not in operation. It may be necessary to drain the pump casing during shutdown periods by removing the bottom drain plug.

Mechanical Seal Maintenance

The mechanical seal require flushing which is flushed from discharge of the pump through a flush line. A throttle bush isolates the mechanical seal from the liquid in the pump. Since mechanical seals need a film of liquid between the sealing faces, pump must not be run unless properly filled with liquid for intended operation.

A 'weep' sound may be heard from mechanical seals at start-up. The pump should run for approximately 8-10 hours, which is the break-in period for seal. During this operation the mechanical seal would 'seat' properly.

Pentair Aurora* 382B CC pump is supplied with mechanical seal type 21

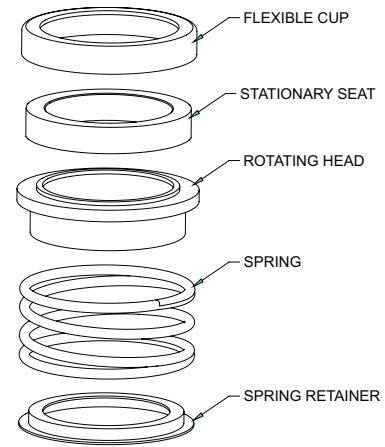

Mechanical Seal Type 21

Figure 7

Recommended Spare Part List

Although all the components could be procured by the customer at short interval, to reduce downtime the below mentioned components should be kept handy in case the pump is to be shut down for maintenance. The components are:

- Mechanical seal
- Wear rings (if applicable)
- Gaskets, O-rings, seals

Consumables

Following items are of regular use during preventive and accidental maintenance and must be kept in stock by the customer:

- Lubricants
- Cleaning materials
- Touch up coating

Required Tools and Fixtures

Pump assembly and disassembly can be performed by using standard hand tools available in market. For quick reference, tools required for disassembly of various pump components are mentioned in Table 3 on the next page. Refer to the exploded pump diagram (Figure 17 on page 15) for item numbers.

PUMP MAINTENANCE AND SERVICE

Table 3

QUICK REFERENCE FOR TOOLS AND FIXTURES

Item no.	Motor frame	Pumps	Wrench size and type (in inches)
4 & 4A	ALL	ALL	9/16" wrench
#5	ALL	7"	9/16" wrench
		9.5", 11"	3/4" wrench
		13.5"	1-1/2" wrench
5B	143-184	9.5", 11", 12", 13.5"	9/16" wrench
	213-215	9.5", 11", 12", 13.5"	
	254-256	9.5", 11", 13.5"	
	284-326	9.5", 11", 13.5"	
	364-405	9.5"	3/4" wrench
	444-449	9.5"	
#9	143-215	7", 9.5", 11", 13.5"	9/16" socket wrench
	254-326 364-449	7", 9.5", 11", 13.5"	3/4" socket wrench
	143-184	7", 9.5"	9/16" wrench
#32	213-215 254-256	7", 9.5", 11", 13.5"	3/4" wrench
	284-326 364-405 444-449	7", 9.5", 11", 13.5"	1-1/2" wrench

In addition to the tools mentioned above, some additional equipment and fixtures may be required which are mentioned below:

- Lifting devices (crane, hoist, lifting chains or straps)
- Impeller puller (to remove pressed-on impeller from shaft)
- Torch (to heat parts to aid in removal)
- Die grinder (to cut out wear rings or sleeves, if needed)
- Work table or fixture (for holding pump)
- Measuring equipment (feeler gauges, dial indicator, etc.)

Fastener Torque and Sequence

Proper tightening of bolting is very important. Torque values will vary depending on the size and grade of bolting used.

REPAIRS

NOTICE: READ AND UNDERSTAND ALL SAFETY WARNINGS AT THE BEGINNING OF THE MANUAL BEFORE BEGINNING INSTALLATION OR ANY REPAIR WORK.

This repairs section is broken into two parts. The first part covers the dismantling of the mechanical seal and complete pump disassembly. The second part covers installation of mechanical seal and complete pump assembly. Refer to the exploded pump diagram (Figure 17 on page 15) for item numbers.

Disassembly

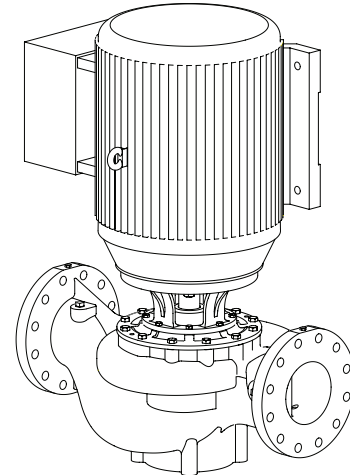

Figure 8

⚠ WARNING Sudden start-up hazard: Disconnect and lock out power source before servicing. Failure to follow these instructions could result in serious personal injury, death or property damage.

1. Ensure the electrical power is locked out, the system pressure has been lowered and temperature of the unit is at a safe level.
2. Isolate the pump from the system by closing the valves that should be located on the suction and discharge side of the pump.
3. Loosen plugs (#4A) from casing and drain the pump

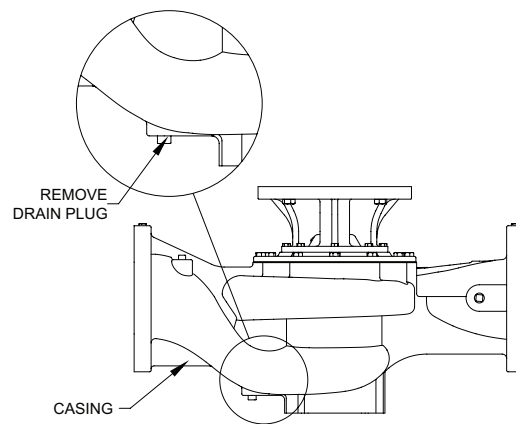

Figure 9

⚠ WARNING Hot surface hazard: If pumping hot water, ensure guards or proper insulation is installed to protect against skin contact with hot piping or pump components. Failure to follow these instructions could result in serious personal injury, death or property damage.

⚠ WARNING Spraying water hazard: When servicing pump, replace all gaskets and seals. Do not reuse old gaskets or seals. Failure to follow these instructions could result in serious personal injury, death or property damage.

⚠ WARNING High pressure hazard: All pumps are designed for specific maximum working pressure. Do not exceed this pressure. Install properly sized pressure relief valves in system. Failure to follow these instructions could result in serious personal injury, death or property damage.

PUMP MAINTENANCE AND SERVICE

4. Remove all relief, cooling, flushing, or drain lines from the pump, including compression connectors (#1 and #2) and tubing (#3). Break suction and discharge connections only if it is desired to remove casing (#6).
5. Loosen the casing cap screws (#5) connecting the seal plate (#35A). Do not remove them. Utilize two of the casing cap screws to jack the motor assembly from the casing (#6).

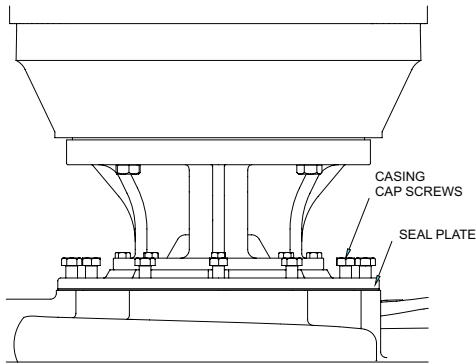

Figure 10

6. Lift the motor assembly straight up (see Figure 11 shown below) from the casing.

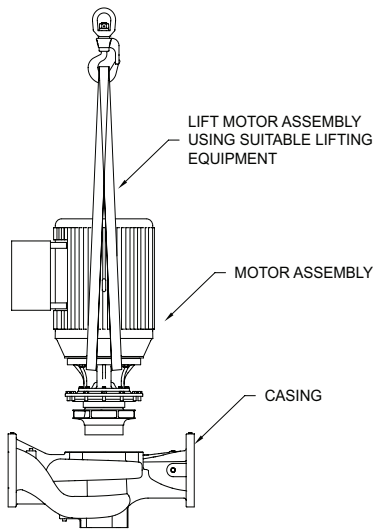

Figure 11

7. Remove casing gasket (#8).
8. Unscrew impeller screw (#9) and remove impeller washer (#9A), impeller gasket (#9B) and impeller seal (#9C).
9. Slide impeller (#11) and impeller key (#12) from shaft.
If wear ring needs to be removed, follow step 10 otherwise continue with step 11.
10. Wear ring (#7) is pressed into the housing with an interference fit, and must be removed with a puller. New ring should be used for reassembly.
11. Slide sleeve (#25) and O-ring (#10) with the rotating parts of the mechanical seal (#27) from the shaft.

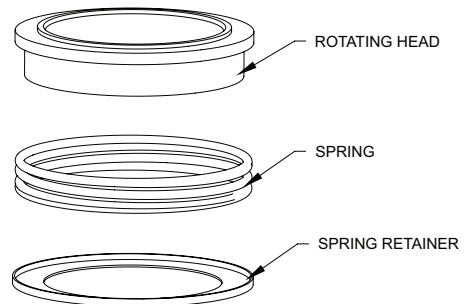

Figure 12
(Rotating parts of mechanical seal)

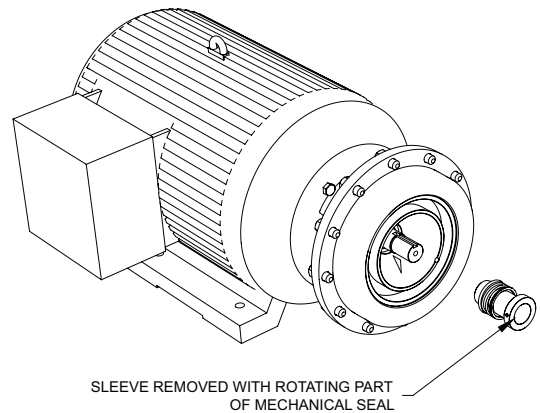
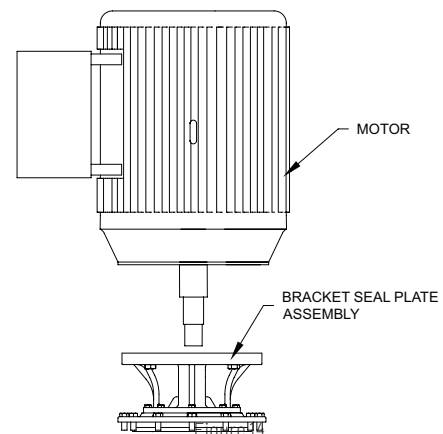

Figure 13

12. The sleeve (#25) should be carefully cleaned to remove any residue that may be remaining in the seal area. The rubber in the seal (#27) may have been partially adhered to the sleeve. The sleeve must also be checked for abrasion or corrosion that can occur when fluid residue penetrates between the seal (#27) and the sleeve (#25). The sleeve under the seal may be polished lightly to a 32 RMS finish before reassembly. Do not reuse a pitted sleeve. Pin (#61) may be removed if necessary.

⚠ CAUTION The mechanical seal is a precision product and must be treated as such. During removal, great care must be taken to avoid dropping any part of the seal. Take particular care not to scratch the lapped faces on the washer or the sealing seat. Do not put a seal back into service until the sealing faces of the washer and the seat have been lapped or replaced.

13. Unscrew cap screws (#5) with washer (#5A) and remove bracket (#35B) - seal plate (#35A) assembly from the motor.



PUMP MAINTENANCE AND SERVICE

14. Unscrew cap screws (#5B) holding motor bracket (#35B) and seal plate (35A) if any repair is required or for ease of replacing mechanical seal.
15. The seal flexible cup and stationary seat should be pressed out of the seal plate and the cavity cleaned of all residues. Make sure that the 1/32 inch radius in the seal cavity is not damaged during disassembly since sharp edge can easily cut the flexible cup during reassembly.

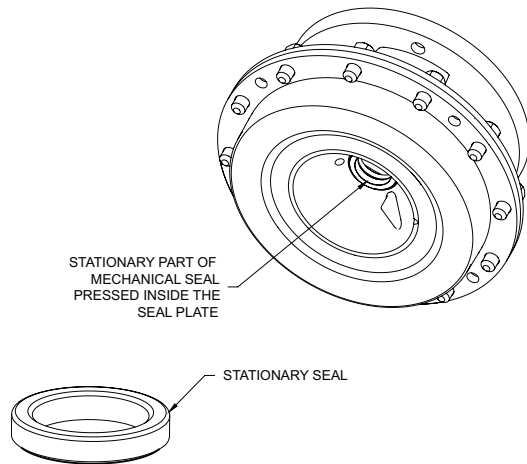

Figure 15

7. Remove name plate (#34) and screws (#33) only if replacement is needed.

Inspection

Once the pumping unit is disassembled, component parts should be inspected to determine their condition. Worn parts should be reconditioned to like-new condition or replaced.

Assembly

1. Reassembly will generally be in reverse order of disassembly. If disassembly was not complete, use only those steps related to your particular repair program
2. The mechanical seal (#27) cannot be installed as an assembly. It is necessary to have the seal seat properly in place before the balance of parts can be added. Thoroughly inspect the seal cavity in the seal plate for burrs or nicks which could damage the seat of the seal. Apply a film of soap past or flax soap (do not use oil or grease) to the seal seat and install, taking care to seat it evenly and squarely.
NOTICE: If it is not possible to insert seat with fingers, place cardboard to protecting ring furnished with seal over lapped face of seat and press into place with a piece of tubing having end cut square. The tubing should be slightly larger than the diameter of the shaft. Remove cardboard after seat is firmly in place.
3. Position seal plate (#35A) on motor bracket (#35B) and secure with cap screws (#5B).
4. Position seal plate-bracket assembly (#35) on the motor and secure with cap screws (#5) and washers (#5A). Tighten screws evenly to assure alignment.
5. If name plate was removed, install and attach with screws (#33).

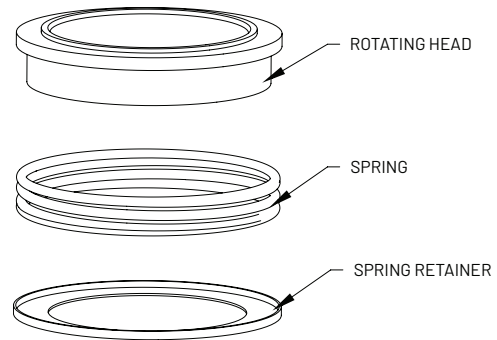

Figure 16

(Rotating parts of mechanical seal)

6. Wipe the sealing faces of the seat and seal washer clean. Oil these surfaces with clean light oil. Lightly oil the shaft sleeve (#25). The shaft sleeve with the seal rotating assembly on it may now be replaced on the motor shaft. Spring tension will probably prevent the sleeve from remaining in position axially until the impeller is locked against it.
NOTICE: If wear ring is to be installed, follow step 7 otherwise continue with step 8.
7. Press wear ring (#7) in casing. Rings should be hammered into place. Use press, or clamp the parts in a bench vise, using wooden block to protect the rings. It may be necessary to pin or dowel the rings after assembly.
8. Carefully place O-ring gasket (#10) on the motor end of impeller. Assemble key (#12) and impeller (#11) to motor shaft. Secure impeller with impeller gasket (#9B), impeller washer (#9A), impeller seal (#9C) and impeller screw (#9).
9. Install the four pipe plugs (#4), (#4A) in the pump casing. Position the gasket (#10) and casing (#6) against the seal plate (#35A) and secure with screws (#5).
10. Replace all relief, cooling, flushing, or drain lines to the pump including compression connectors (#1 and #2) and tubing (#3). Connect discharge piping and suction piping if required. Make sure to install gaskets on flanged connections. Connect electricity to motor.

NOTICE: Read starting instructions (See "Starting Up" on Page 8) before attempting to start the pump.

TROUBLESHOOTING GUIDE

THE FOLLOWING IS A LIST OF COMMON PROBLEMS AND THEIR PROBABLE CAUSES.

Symptoms	Possible causes	Possible remedies	
Insufficient pressure or Insufficient/no flow	Speed too low	Check and ensure correct voltage at motor terminals Check if rotating elements freely rotate	
	Wrong direction of rotation	Check motor rotation with direction arrow on casing Ensure correct motor wiring	
	Entrained air in pump	Ensure all air is vented, and pump is adequately primed Ensure eccentric reducer, if correctly installed	
	Air leaks into suction line	Tighten the suction piping flange bolts as required	
	Leaking joints	Check for any external leakage and arrest	
	Excessive leakage from seal	Inspect and replace mechanical seal, as required	
	Insufficient submergence of suction pipe	Check and ensure sufficient pipe length, submerged well below the water surface	
	Insufficient pressure at pump inlet	Ensure correct suction pipe sizing Raise fluid level or move pump closer to the water level	
	Clogged impeller	Clean impeller as required	
	Damaged impeller	Check and replace impeller as required	
	Worn wear rings	Check and replace wear rings, if equipped	
	System head not as anticipated	Contact manufacturer for correct pump sizing	
	Smaller impeller diameter	Contact manufacturer for correct impeller sizing	
	Excessive power consumption	Speed too high	Check and ensure correct voltage at motor terminals
		Rubbing or binding of rotating elements	Check if rotating elements are not rubbing against stationary components
Shaft bent		Inspect shaft for any deformation and replace	
Worn wear rings		Check and replace wear rings, if equipped	
Head lower than rating, pumps too much liquid		Contact manufacturer for correct pump/impeller sizing	
Abnormal noise and vibration	Coupling misalignment	Check and ensure alignment between pump and driver shaft	
	Foundation/grouting not rigid	Ensure foundation is adequately sized and rigid to absorb the vibrations Ensure foundation bolts are tightened to adequate torque	
	Defective bearings	Check motor and/or pump for worn bearings, and replace as required	
	Rubbing or binding of rotating elements	Check if rotating elements are not rubbing against stationary components	
	Pump operating outside Allowable Operating Region (AOR)	Ensure the pump is being operated within its Allowable Operating region. Contact manufacturer for correct pump sizing.	
	Entrained air in pump	Ensure all air is vented, and pump is adequately primed Ensure eccentric reducer, if correctly installed	
	Insufficient pressure at pump inlet	Ensure correct suction pipe sizing Raise fluid level or move pump closer to the water level	

TROUBLESHOOTING GUIDE

Motor fails to start	Incorrect wiring	Check motor wiring against motor wiring diagram (on motor)
	Wrong voltage	Check and ensure correct voltage at motor terminals
	Switches not set	Set switches ON
	Tripped thermal overload relay	Set relays ON
	Blown fuses	Replace fuses
	Loose or broken wiring	Check and tighten connections. Replace broken wiring
	Binding of rotating elements	Check if rotating elements freely rotate
	Defective motor	Check and replace motor
Motor runs hot	Speed too high	Check and ensure correct voltage at motor terminals
	Voltage lower than rated	Check and ensure correct voltage at motor terminals
	Rubbing or binding of rotating elements	Check if rotating elements are not rubbing against stationary components

Note: The pump delivered may not be fitted with all the components mentioned in the troubleshooting guide.

ASSEMBLY EXPLODED VIEW

PENTAIR AURORA* MODEL 382B CC

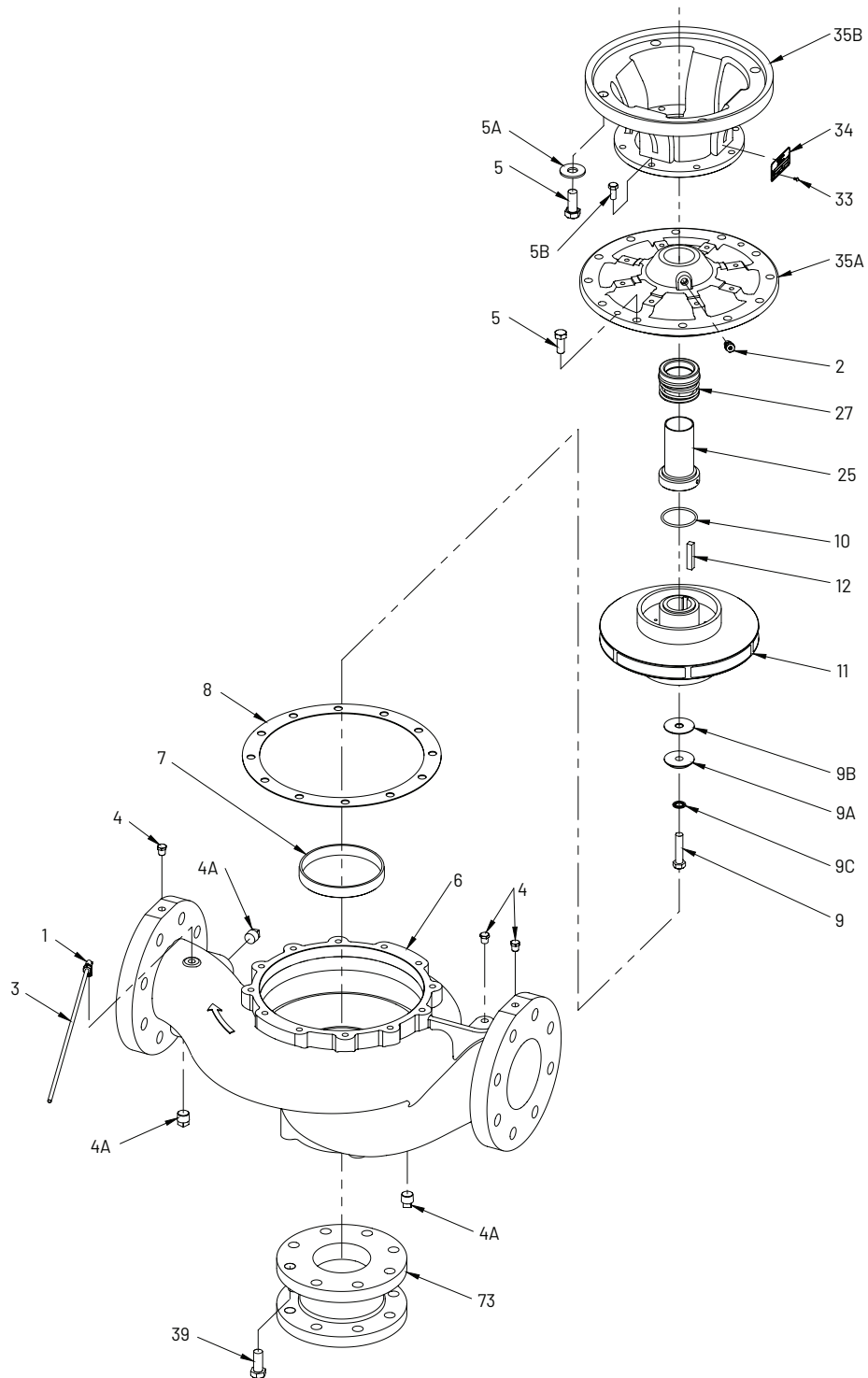

Figure 17

PART LIST

PENTAIR AURORA* 382B CC VERTICAL IN-LINE PUMPS

Reference: Figure 17 (Exploded View)

ITEM NO.	DESCRIPTION
1	COMPRESSION ELBOW
2	COMPRESSION CONNECTOR
3	TUBING
4	PIPE PLUG
4A	PIPE PLUG
5	CAP SCREW
5A	WASHER
5B	CAP SCREW
6	CASING
7	WEAR RING
8	GASKET
9	IMPELLER SCREW
9A	IMPELLER WASHER
9B	IMPELLER GASKET
9C	IMPELLER SEAL
10	O-RING GASKET
11	IMPELLER
12	IMPELLER KEY
25	SLEEVE
27	MECHANICAL SEAL
33	SCREW
34	NAME PLATE
35A	SEAL PLATE
35B	MOTOR BRACKET
39	CAP SCREW
61	PIN
73	SPOOL BASE

STANDARD LIMITED WARRANTY

WARRANTY

Seller warrants equipment (and its component parts) of its own manufacture against defects in materials and workmanship under normal use and service for one (1) year from the date of installation or start-up, or for eighteen (18) months after the date of shipment, whichever occurs first. Seller does not warrant accessories or components that are not manufactured by Seller; however, to the extent possible, Seller agrees to assign to Buyer its rights under the original manufacturer's warranty, without recourse to Seller. Buyer must give Seller notice in writing of any alleged defect covered by this warranty (together with all identifying details, including the serial number, the type of equipment, and the date of purchase) within thirty (30) days of the discovery of such defect during the warranty period. No claim made more than 30 days after the expiration of the warranty period shall be valid. Guarantees of performance and warranties are based on the use of original equipment manufactured (OEM) replacement parts. Seller assumes no responsibility or liability if alterations, non-authorized design modifications and/or non-OEM replacement parts are incorporated. If requested by Seller, any equipment (or its component parts) must be promptly returned to Seller prior to any attempted repair, or sent to an authorized service station designated by Seller, and Buyer shall prepay all shipping expenses. Seller shall not be liable for any loss or damage to goods in transit, nor will any warranty claim be valid unless the returned goods are received intact and undamaged as a result of shipment. Repaired or replaced material returned to customer will be shipped F.O.B., Seller's factory. Seller will not give Buyer credit for parts or equipment returned to Seller, and will not accept delivery of any such parts or equipment, unless Buyer has obtained Seller's approval in writing. The warranty extends to repaired or replaced parts of Seller's manufacture for ninety (90) days or for the remainder of the original warranty period applicable to the equipment or parts being repaired or replaced, whichever is greater. This warranty applies to the repaired or replaced part and is not extended to the product or any other component of the product being repaired. Repair parts of its own manufacture sold after the original warranty period are warranted for a period of one (1) year from shipment against defects in materials and workmanship under normal use and service. This warranty applies to the replacement part only and is not extended to the product or any other component of the product being repaired. Seller may substitute new equipment or improve part(s) of any equipment judged defective without further liability. All repairs or services performed by Seller, which are not covered by this warranty, will be charged in accordance with Seller's standard prices then in effect.

THIS WARRANTY IS THE SOLE WARRANTY OF SELLER AND SELLER HEREBY EXPRESSLY DISCLAIMS AND BUYER WAIVES ALL OTHER WARRANTIES EXPRESSED, IMPLIED IN LAW OR IMPLIED IN FACT, INCLUDING ANY WARRANTIES OF MERCHANTABILITY OR FITNESS FOR A PARTICULAR PURPOSE. Seller's sole obligation under this warranty shall be, at its option, to repair or replace any equipment (or its component parts) which has a defect covered by this warranty, or to refund the purchase price of such equipment or part. Under the terms of this warranty, Seller shall not be liable for (a) consequential, collateral, special or liquidated losses or damages; (b) equipment conditions caused by normal wear and tear, abnormal conditions of use, accident, neglect, or misuse of said equipment; (c) the expense of, and loss or damage caused by, repairs or alterations made by anyone other than the Seller; (d) damage caused by abrasive materials, chemicals, scale deposits, corrosion, lightning, improper voltage, mishandling, or other similar conditions; (e) any loss, damage, or expense relating to or resulting from installation, removal or reinstallation of equipment; (f) any labor costs or charges incurred in repairing or replacing defective equipment or parts, including the cost of reinstalling parts that are repaired or replaced by Seller; (g) any expense of shipment of equipment or repaired or replacement parts; or (h) any other loss, damage or expense of any nature.

The above warranty shall not apply to any equipment which may be separately covered by any alternate or special warranties.

PERFORMANCE: In the absence of Certified Pump Performance Tests, equipment performance is not warranted or guaranteed. Performance curves and other information submitted to Buyer are approximate and no warranty or guarantee shall be deemed to arise as a result of such submittal. All testing shall be done in accordance with Seller's standard policy under Hydraulic Institute procedures.

LIABILITY LIMITATIONS: Under no circumstances shall the Seller have any liability under the Order or otherwise for liquidated damages or for collateral, consequential or special damages or for loss of profits, or for actual losses or for loss of production or progress of construction, regardless of the cause of such damages or losses. In any event, Seller's aggregate total liability under the Order or otherwise shall not exceed the contract price.

ACTS OF GOD: Seller shall in no event be liable for delays in delivery of the equipment or other failures to perform caused by fires, acts of God, strikes, labor difficulties, acts of governmental or military authorities, delays in transportation or procuring materials, or causes of any kind beyond Seller's control.

COMPLIANCE WITH LAW: Seller agrees to comply with all United States laws and regulations applicable to the manufacturing of the subject equipment. Such compliance shall include: The Fair Labor Standards Acts of 1938, as amended; Equal Employment Opportunity clauses of Executive Order 11246, as amended; Occupational Safety and Health Act of 1970 and the standards promulgated thereunder, if applicable. Since compliance with the various Federal, State, and Local laws and regulations concerning occupational health and safety, pollution or local codes are affected by the use, installation and operation of the equipment and other matters over which Seller has no control, Seller assumes no responsibility for compliance with those laws and regulations, whether by way of indemnity, warranty, or otherwise. It is incumbent upon the Buyer to specify equipment which complies with local codes and ordinances.



800 Airport Road | North Aurora, Illinois 60542 | Ph: 630.859.7000 | pentair.com

*For a detailed list of where Pentair trademarks are registered, please visit www.pentair.com/en/registrations.html. Pentair trademarks and logos are owned by Pentair PLC. or its affiliates. Third party registered and unregistered trademarks and logos are the property of their respective owners. Because we are continuously improving our products and services, Pentair reserves the right to change specifications without prior notice. Pentair is an equal opportunity employer.

AU1064 (09/27/19) ©2019 Pentair. All Rights Reserved.