

INSTRUCTION AND REPAIR MANUAL

HORIZONTAL TWO-STAGE DIAGONAL PUMP

Model
431B

ENGLISH: PAGES 2-12

INSTRUCTION AND REPAIR MANUAL

NOTE! To the installer: Please make sure you provide this manual to the owner of the equipment or to the responsible party who maintains the system.



THIS PAGE INTENTIONALLY LEFT BLANK

CALIFORNIA PROPOSITION 65 WARNING:

▲ WARNING This product and related accessories contain chemicals known to the State of California to cause cancer, birth defects or other reproductive harm.

SERVICE

Your Aurora pump requires no maintenance other than periodic inspection, lubrication and occasional cleaning. The intent of inspection is to prevent breakdown, thus obtaining optimum service life.

LUBRICATION OF BEARINGS

Model 431B pump is available with four options for lubricating and shaft bearings. They are:

1. Regreasable (standard)
2. Oil Lubrication
3. Regreasable, Water-Cooled
4. Oil Lubrication, Water-Cooled

Regreasable bearings will require periodic lubrication and this can be accomplished by using the zerk or lubrication fitting at each bearing. Lubricate the bearings at regular intervals using high quality grease. The initial bearing lubrication at Aurora is Chevron SRI Grease NLGI 2 (polyurea thickener) (Pentair Part Number 384-0002-639). Before lubricating the bearings, thoroughly flushing the old grease with the new grease is required. We recommend Chevron SRI Grease NLGI 2 (polyurea thickener) for follow-up re-lubrication after the flushing. Most major brands of Grade No. 2 ball bearing grease are satisfactory for pump operation in both wet and dry applications.

CAUTION

Be aware that mixing of different brands or blends of grease should be avoided due to possible incompatibilities that could damage the bearings. A thorough flushing of the old grease with the new grease is required to minimize this potential incompatibility. Avoid using the following: (1) grease of vegetable or animal base that can develop acids or (2) grease containing rosin, graphite, talc or other impurities. Under no circumstances should grease be reused.

CAUTION

Over lubrication should be avoided as it may result in overheating and possible bearing failure. Under normal application, adequate lubrication is assured if the amount of grease is maintained at 1/3 to 1/2 the capacity of the bearing and adjacent space surrounding the bearing.

In dry locations, each bearing will need lubrication at least every 4,000 hours of running time or every 6 to 12 months, whichever is more frequent. In wet locations the bearings will need lubrication at least after every 2,000 hours of running time or every 4 to 6 months, whichever is more frequent. A unit is considered to be installed in a wet location if the pump and motor are exposed to dripping water, to the weather, or to heavy condensation such as found in unheated and poorly ventilated underground locations.

At times it may be necessary to clean the bearings due to accumulated dirt or deteriorated lubricants. This can be accomplished by flushing the bearing with a light oil heated to 180 to 200° F. while rotating it on a spindle. Wipe the bearing housing with a clean rag soaked in a cleaning solvent, and flush all surfaces.

Dry bearing thoroughly before relubricating. Compressed air can be used to speed drying, but care should be taken not to let bearings rotate while being dried.

CAUTION

Use normal fire caution procedures when using any petroleum cleaner.

The motor which drives your Aurora pump may or may not require lubrication. Consult the manufacturer's recommendations for proper maintenance instructions.

REPAIRS

The pump may be disassembled using the illustrations and text provided. Although complete disassembly is covered, it will seldom be necessary to completely disassemble your Aurora pump.

The illustrations accompanying the disassembly instructions show the pump at various stages of disassembly. The illustrations are intended to aid in the correct identification of the parts mentioned in the text.

Inspect removed parts at disassembly to determine their reusability. Cracked castings should never be

reused. All optional packing and gaskets should be replaced with new ones at reassembly simply as a matter of economy; they are much less expensive to replace routinely than to replace as the need occurs. In general it is economical to return to the manufacturer for repair only the motor and motor controller.

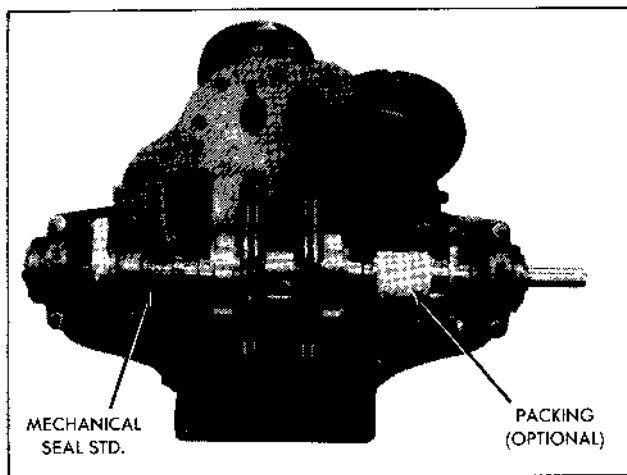

A. Upper casing, gland halves, and bearing cap removed.

Disassembly of Model 431B (Refer to Figure 4.)

1. Break the electrical connection to motor or take similar steps to make certain that drive unit will not be unintentionally energized during disassembly.

2. Close such valves or flow-control devices necessary to make certain that flow of liquid will not take place during disassembly.

Note

Discharge and suction piping need not be disturbed unless complete pump assembly is to be removed.

3. Drain liquid from pump by removing plugs (1 and 2). Disconnect by-pass lines if applicable.

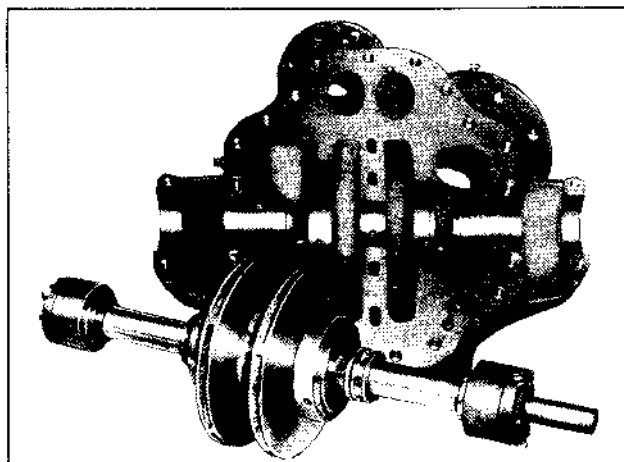

B. Rotating element removed from lower casing.

4. Loosen and remove capscrews (6) securing upper casing (8) to remainder of pump assembly.

NOTE

Disassembly procedure from this point covers pumps having standard mechanical seals. If pump has optional packing, refer to specific instructions located at the end of the disassembly instructions.

5. Loosen and remove nuts (18), washers (19), and clamps (20) holding gland to casing.

CAUTION

Use extreme care in loosening nuts and freeing gland. Gland is under spring pressure from the mechanical seal. Nuts (18) should be loosened evenly to allow gland to separate from casing evenly. To prevent damage to stationary mechanical seal seat, mounted in gland, the gland should be wrapped in a clean shop cloth or other protective coating to prevent the seat from hitting the shaft during movement of the rotating assembly.

6. Loosen and remove capscrews (7) at stuffing box and remove swing bolts (22).

7. Making certain that all securing capscrews are removed, carefully remove upper casing (8) using hoist or crane with sling attached to cast hooks.

8. Remove gasket (9) and scrape mating surfaces of casing halves to remove pieces of gasket which may have adhered in separation. Take care not to scratch or mar surface of casing halves.

9. Separate couplings connecting pump shaft and motor.

10. Remove the four capscrews (25) securing the two bearing caps (26). Mark both caps to insure correct replacement and orientation on the respective bearing arms. **NOTE:** Bearing caps must be replaced as installed by the factory or premature bearing failure could result. Lift off bearing caps (26) and pins (27).

11. Assuming that further work is required on shaft and impeller assembly, use properly secured rope slings and hoist or crane as required to lift it from lower pump casing (74) and place it on suitable bench or work surface.

CAUTION

Take care not to dent or damage impeller and/or other parts. Use of a supporting cradle or work stand is recommended.

12. Slide pump half of flexible coupling off shaft (71) and remove key (24). Pry up on end of key so as not to damage shaft. If preferred, key may be removed by carefully tapping from outer end with a brass drift or similar non-marring tool, using a small hammer.

13. Remove casing wearing rings (28).

14. With shaft and impeller assembly on a suitable bench, cradle, or work stand, loosen and remove pipe plug (12) and grease zerks (10) from cartridge caps (32 and 42). If pump has oil lubrication option, remove breather cap from top of cartridge caps and remove oiler and connecting nipple. If pump has water-cooled option, remove water inlet and outlet piping.

15. Loosen and remove capscrews (31) from cartridge cap (32). Outboard shaft end protector (29) may be removed from its recess in outboard cartridge cap at this time if necessary.

For pumps equipped with water-cooled bearing caps, loosen and remove capscrews (31 and 89) and cover plate (84) from cartridge. Remove the four capscrew sealing "O" rings (81 - PS #2 only), along with the ID "O" ring (82) and OD "O" ring (83) from the cartridge caps (32).

16. Loosen and remove locknut (77) and slide lock washer (35) off of outboard end of shaft. Outboard bearing (38) is press fitted onto shaft (70). To remove it, place a bearing puller on bearing cartridge (36) and pull cartridge, lip seal (37), and bearing from shaft. Bearing can then be removed from cartridge and lip seal pressed out of cartridge.

17. Remove inboard bearing (47) using a bearing puller in the identical fashion as the outboard bearing.

18. One piece gland (49) used with mechanical seal assembly can now be removed from shaft. "O" ring (50) can be removed from seal gland along with the mechanical seal stationary seat.

CAUTION

Exercise great care in removing seal assembly (53) to keep from marring or otherwise damaging precision ground mating surfaces where it meets seal collar (54).

19. Scribe a mark on shaft sleeves for relocating seal collar on reassembly. Loosen setscrews (55), securing seal collars (54) to shaft sleeves and slide them off.

20. If unit has right hand rotation, unscrew and remove outboard sleeve (57) first. Remove "O" ring (58). If unit has left hand rotation, unscrew and remove inboard sleeve (65). Remove "O" ring (66).

21. On right hand unit, balance of the parts will be removed as follows: Pull or tap impeller (59) off shaft (71) using care not to damage impeller. Remove "O" ring (60). Slide casing bushing (61) off separator sleeve (62). Pull separator sleeve, "O" ring (64), and impeller (67) off shaft. Remove "O" ring (66) and key (68). Unscrew and remove shaft sleeve (65).

Left hand unit disassembly will begin with impeller (67) and end with sleeve (58).

22. Remove locking and locating pins (63, 69 and 72) from lower casing half (74).

23. Nameplate (76) and its securing screws (75) should only be removed if replacement is necessary.

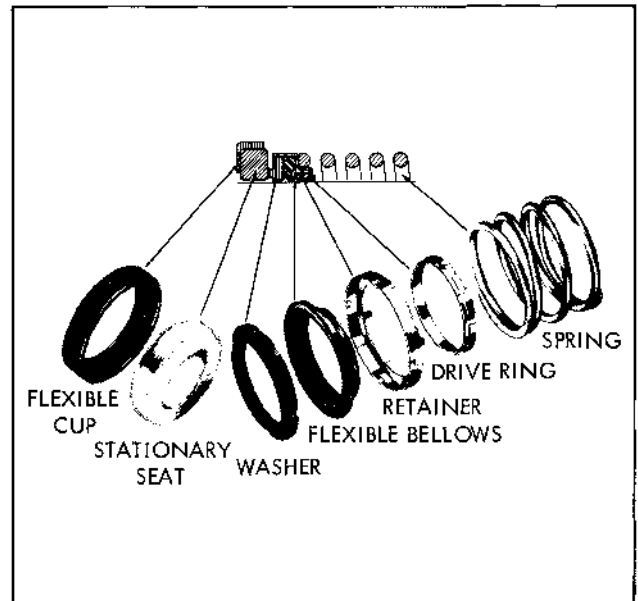

Figure 1. Mechanical Seal

Disassembly of Pumps with Optional Packing

1. Disassembly of pumps equipped with packing will be similar to disassembly of pumps equipped with mechanical seals except as follows.

2. The gland (21) is of split design that can be removed after the nuts (18) are sufficiently loosened to allow the gland clamp (20) to slide off gland ears.

3. After the cartridges and slingers are removed, slide the six ring packing set (23) off the shaft. Slide the throttle bushing (56) off the shaft. Used packing sets should be replaced during any pump repair operation. These packing sets consist of two different types of high temperature packing rings. The sets consist of 6 rings arranged with metallic and plastic packing rings in the order of metallic-plastic-plastic-metallic-plastic-metallic. This is the order of the rings from the impeller side of the stuffing box to the gland end of the stuffing box.

Reassembly of Model 431B (Refer to Figure 4.)

Reassembly will generally be in reverse order of disassembly. If disassembly was not complete, use only those steps related to your particular repair program.

1. Position locating pins (72) in lower casing (74). Install wearing ring pins (69) and casing bushing pins (63). Tap pins gently to seat them in place.

If nameplate (76) was removed, install it with screws (75).

MODEL 431B

TWO STAGE PUMP SHAFTS
LOCATION OF SHAFT SLEEVE ON SHAFT
R.H. ROTATION

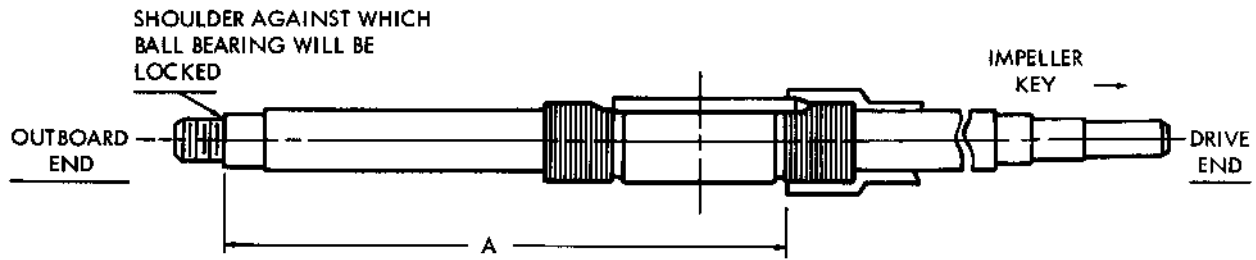

POWER SERIES	PUMP SIZE	A
2	1-1/2 x 3 x 9 2 x 4 x 9	12-49/64
3A	1-1/2 x 3 x 11 2 x 4 x 11	14-59/64

Figure 2

TWO STAGE PUMP SHAFTS
LOCATION OF SHAFT SLEEVE ON SHAFT
L.H. ROTATION

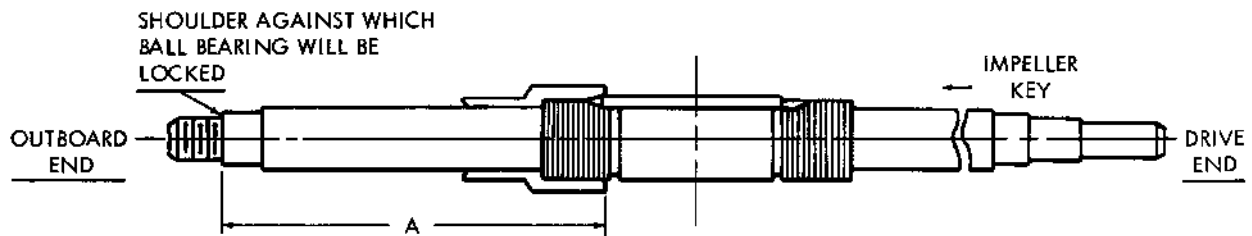

POWER SERIES	PUMP SIZE	A
2	1-1/2 x 3 x 9 2 x 4 x 9	6-57/64
3A	1-1/2 x 3 x 11 2 x 4 x 11	7-59/64

Figure 3

2. On a right hand unit, thread inboard sleeve (65) onto shaft (71) distance "A" (refer to Figure 2). On a left hand unit, thread outboard sleeve (57) onto shaft distance "A" (refer to Figure 3). When the sleeve is in position, its keyway should align with keyway on shaft. Coat key and keyway with Loctite Sealant Grade 242. Insert key (68) into keyways of shaft and sleeve. Tap key firmly in place.

3. On right hand unit proceed to assemble the rotating element as follows:

Place "O" ring (66) into groove on face of shaft sleeve (65) and slide impeller (67) onto shaft (71). A small amount of silicon or grease is useful in holding "O" ring into groove until impeller is tightened against it.

Place "O" ring (64) into groove on separator sleeve (62) and slide onto shaft and against impeller. Place casing bushing (61) over separator sleeve. Place "O" ring (60) into groove on separator sleeve and slide impeller (59) in place. Place "O" ring (58) into groove of shaft sleeve (57) and thread shaft sleeve (57) tightly onto shaft (71).

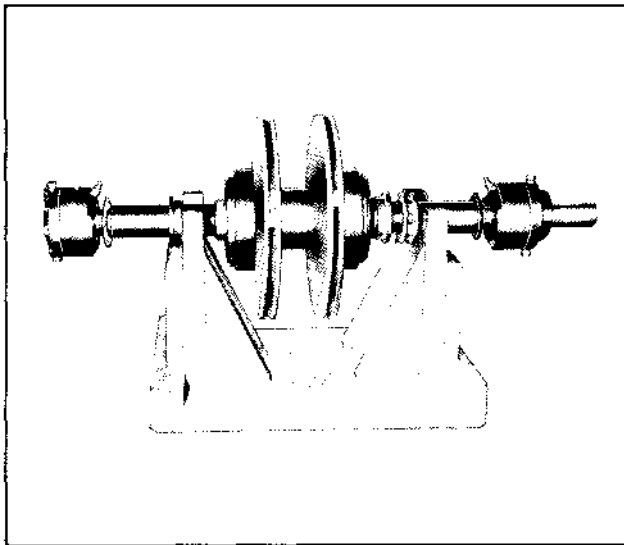

C. Rotating element placed in a protective cradle for further disassembly.

NOTE

When assembling rotating element of a 431A Series Pump it is important that the curve of impeller blades is in agreement with pump rotation.

CAUTION

Carefully check to see that the proper shaft sleeve has been keyed into place for rotation of pump. If the correct shaft sleeve is not keyed onto the shaft, it can spin loose during operation of pump and cause extensive damage.

4. Install mechanical seals and optional packing according to the following specific instructions:

Mechanical Seal, single.

I. Slide one seal lock collar (54) with setscrews (55), with spring shoulder facing away from impeller, onto each end of the shaft. Position on scribe made during disassembly and lock in place.

II. Put a coating of mechanical seal lubricant, or if not available, a blend of non-abrasive dishwashing soap and water on shaft sleeve. Check rotating parts of seal to make sure they are clean. Spread a light coating of the mechanical seal lubricant on inside diameters of flexible bellows.

III. Place the seal's spring first onto the shaft sleeve, followed by the rotating element of the seal, being sure the carbon rotating face is pointed away from the seal lock collar (54).

IV. Thoroughly inspect cavity of seal gland (49) for burrs or nicks which could damage the seat of seal. Liberally apply mechanical seal lubricant to the gland bore as well as to the stationary seat seal. Press the seal seat evenly and squarely into the cavity of the seal gland.

NOTE

If it is not possible to insert seat with fingers, place a cardboard protecting ring furnished with seal over the lapped face of seat and press into place with a piece of tubing having end cut square. Tubing should be slightly larger than the diameter of shaft. Remove cardboard after seat is firmly in place.

CAUTION

Never place a mechanical seal into service after it has been used without replacing or relapping stationary seat and washer faces.

V. Place "O" rings (50) around seal glands (49) and slide seal glands onto ends of shaft.

Optional Packing

- a. Slide throttle bushings (56) onto each end of shaft.
- b. One packing set (23) consisting of 6 rings of high temperature packing is required for each stuffing box. Slide packing set onto shaft in the ring order as noted in the previous section of pump disassembly with optional packing. Confirm that the butt cuts in the packing are staggered so that the pump will not leak excessively.

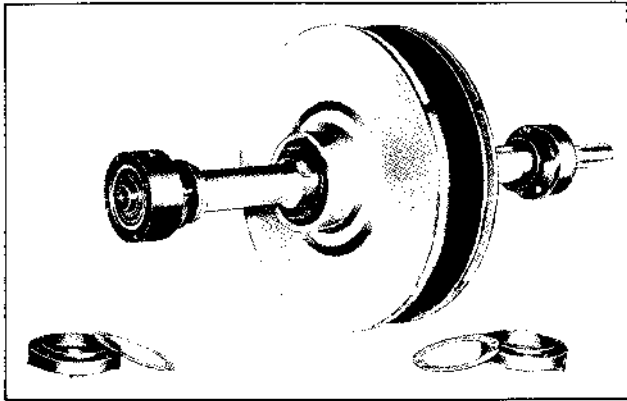

D. Bearing cartridge cap and gasket removed from shaft.

6. Place slinger (39) onto outboard end of shaft (71).

7. Press grease seal (37) into bearing cartridge (36). Place outboard double row ball bearing (38) in bearing cartridge and press parts onto outboard end of shaft until bearing is against shoulder of shaft. Slide bearing lock washer (35) onto the shaft with the concave side facing out. Thread locknut (77) onto shaft and tighten nut until the groove of the nut aligns with one of the tangs of the lock washer (35). Bend the aligned tang into the groove of the lock nut (77). Place gasket (34) and cartridge cap (32) in position and secure it with capscrews (31).

For water-cooled option, position ID "O" ring (82) and OD "O" ring (83) into the grooves located in the cartridge cap (32). Place the four capscrews (31) into the holes of the cover plate (84) and slide the four small bolt "O" rings (81 - PS #2 only) onto the shoulders of the capscrews (31). Place the cover plate (84) onto the cartridge cap (32) insuring the four capscrews (31) pass through the holes in the cartridge cap (32) and lock the cover plate (84) in place using the four small capscrews (89). Place gasket (34) into position on bearing cartridge (36) and secure the cartridge cap/cover plate subassembly to the bearing cartridge using the four capscrews (31) that were previously mounted through the cap.

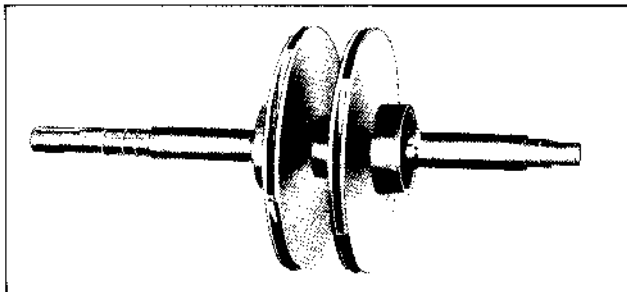

E. Inboard and outboard bearings and bearing cartridges removed.

NOTE

Both grease zerks holes in bearing cartridges and pipe plug holes in cartridge caps must be facing in opposite directions when assembled.

8. Protector (29) can be placed in cartridge cap.

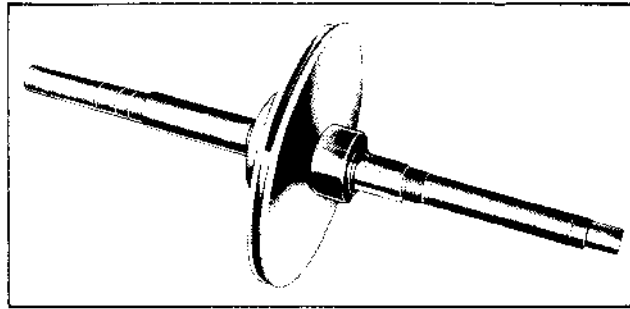

F. Shaft sleeve and outboard impeller removed from shaft.

9. Place slinger (48) on inboard end of shaft.

10. Press grease seal (46) into bearing cartridge (45). Place inboard ball bearing (47) in bearing cartridge and press this assembly onto inboard end of shaft.

11. Press grease seal (43) into cartridge cap (42). Position gasket (44) and cartridge cap against bearing cartridge and secure it in place with capscrews (41). Be sure to align grease zerks holes and pipe plug hole on opposite sides. For water-cooled cap proceed as in step 7.

12. Place grease zerks (10) in bearing cartridges and pipe plugs (12) in bearing caps. If pump is oil lubricated, breather tubes are placed in each bearing cartridge. Oilers with nipple are placed in cartridge caps.

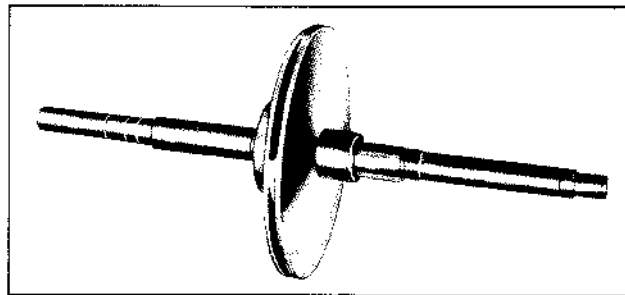

G. Casing bushing removed from impeller separator sleeve.

13. Slide casing wearing rings (28) over impeller suction hubs and set rotating element into lower casing (74). Make certain that drill holes in bottom surface of casing wearing rings are located over pins (69). The drill hole in casing bushing (61) is over pin (63) previously set in lower casing (74).

NOTE

Grease zerks should face up.

14. Install key (24) in motor end of shaft (71). Check positioning and alignment of packing rings or seal components.

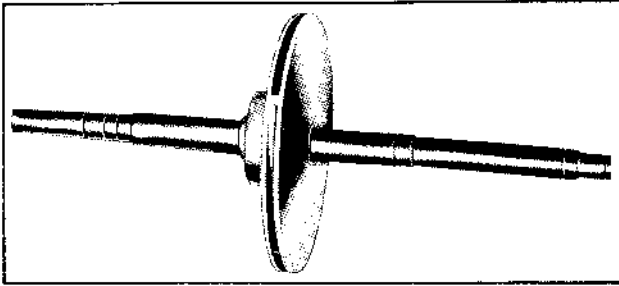

H. Impeller separator sleeve removed from shaft.

15. Place pins (27) into bearing cartridges. Place bearing caps (26) (as marked during disassembly) in position and secure with capscrews (25). Bearing caps must be replaced in the same orientation as before disassembly or premature bearing failure could result.

16. Position new casing gaskets (9) on lower casing (74). Set upper casing (8) in place. Secure it to casing half (74) with capscrews (6). Pins (72) are used as a means of locating the position of casing halves.

17. Install swing bolts (22) and position clamps (20), washers (19), and nuts (18), securing in place with capscrews (7). On mechanical seal equipped pumps, position clamps (20) over ears of gland (49). Tighten nuts (18) evenly until gland is snug against casing. Note that the cover gasket may have to be trimmed at the end of the stuffing box to insure proper sealing of the gland. On optional packed pumps the split gland (21) is to be positioned into the stuffing box and the clamps (20) tightened loosely by use of the nuts (18).

18. Place drain plugs (1) in (2) back in casing halves.

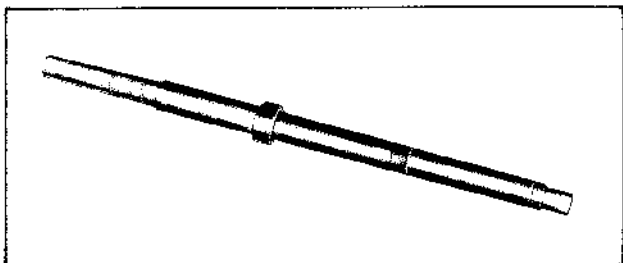

I. Inboard impeller removed. Shaft sleeve in place.

19. If lower casing was removed from base, see instruction manual on Frame Mounted Installation for proper methods of realigning pump to motor and piping.

20. Replace any flushing or cooling lines that were removed. Connect electricity back to motor.

Starting Pump After Reassembly. Do not start pump until all air and vapor have been bled. Bleed air by removing both pipe plugs (2) from the upper casings. Make sure that there is liquid in the pump to provide necessary lubrication.

NOTE

Do not overtighten optional packing assembly before returning unit to operation.

CAUTION

Read operating instructions carefully before starting pump. Jog pump to check for proper rotation. Allow it to run a short time. Gradually tighten nuts (18) on optional packed pumps until dripping has been reduced to its normal level.

Overtightening the packing will make stuffing box overheat causing excessive wear. The shaft sleeve will also receive excessive wear.

MODEL 431B LIST OF PARTS (SEE FIGURE 4)

1. Plug	37. Grease Seal	63. Pin
2. Plug	38. Bearing	64. "O" Ring
6. Capscrew	39. Slinger	65. Sleeve
7. Capscrew	40. Slinger	66. "O" Ring
8. Casing	41. Capscrew	67. Impeller
9. Gasket	42. Cartridge Cap	68. Key
10. Grease Fitting	43. Grease Seal	69. Pin
12. Plug	44. Gasket	71. Shaft
18. Nut	45. Cartridge	72. Pin
19. Washer	46. Grease Seal	74. Casing
20. Clamp	47. Bearing	75. Drive Screw
21. Gland Half	48. Slinger	76. Nameplate
22. Swing Bolt	49. Gland	77. Locknut
23. Packing	50. "O" Ring	79. Comp. Fitting
24. Key	52. Lantern Ring	80. Tubing
25. Capscrew	53. Seal	81. "O" Ring - Bolt (PS #2 only)
26. Bearing Cap	54. Collar	82. "O" Ring - I.D.
27. Pin	55. Setscrew	83. "O" Ring - O.D.
28. Case Ring	56. Bushing	84. Cover Plate
29. Protector	57. Sleeve	85. Oiler
31. Capscrew	58. "O" Ring	86. Nipple
32. Cartridge Cap	59. Impeller	87. Plug
34. Gasket	60. "O" Ring	88. Reducing Bush
35. Lockwasher	61. Bushing	89. Capscrew
36. Cartridge	62. Sleeve	

NOTE

When ordering spare parts always include the pump type, size, serial number, and the piece number from the exploded view in this manual.

Order all parts from your local authorized distributor or the factory at Aurora, Illinois.

MODEL 431B

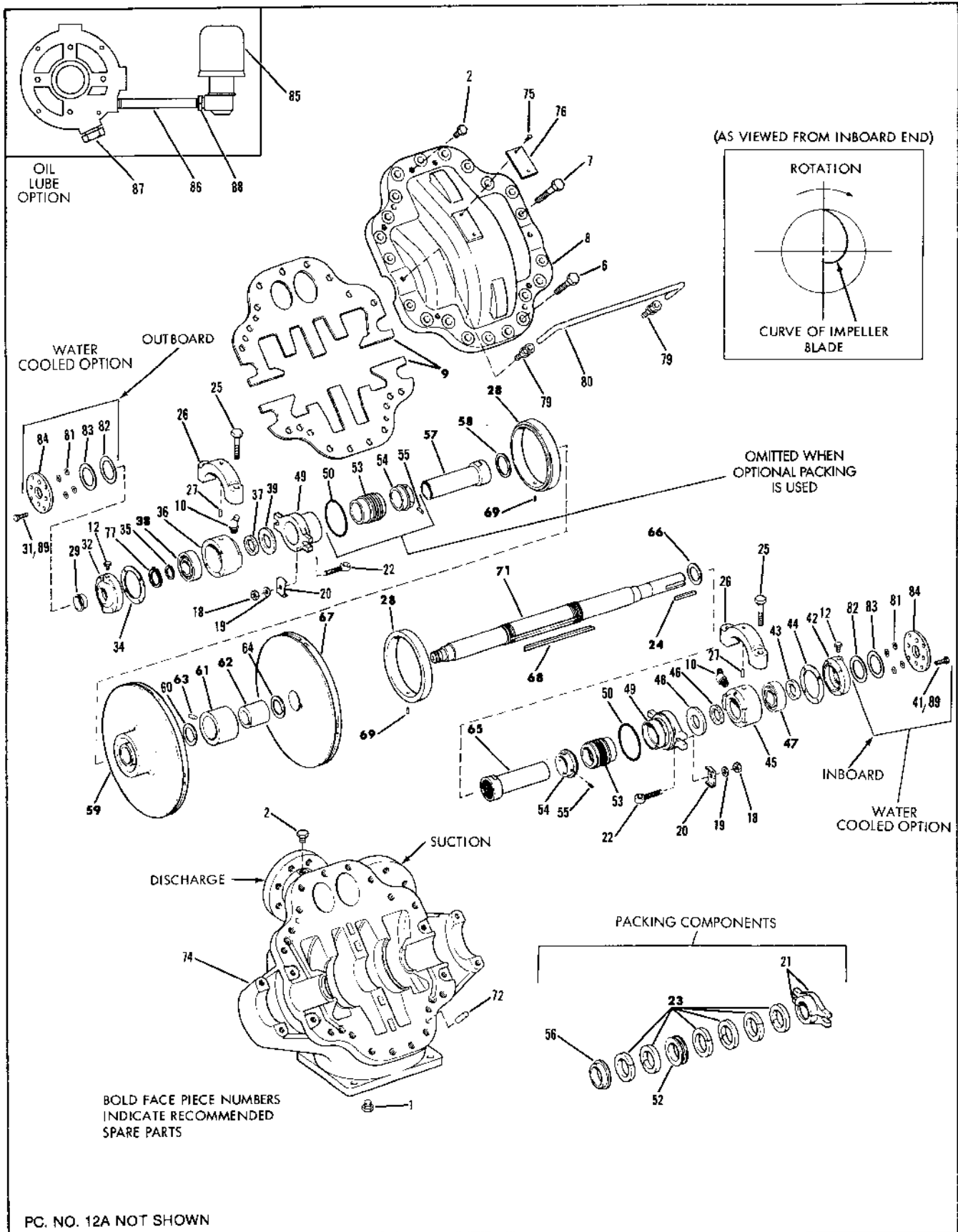

Figure 4. 431B Pump Exploded View

THIS PAGE INTENTIONALLY LEFT BLANK

WARRANTY

Seller warrants equipment (and its component parts) of its own manufacture against defects in materials and workmanship under normal use and service for one (1) year from the date of installation or start-up, or for eighteen (18) months after the date of shipment, whichever occurs first. Seller does not warrant accessories or components that are not manufactured by Seller; however, to the extent possible, Seller agrees to assign to Buyer its rights under the original manufacturer's warranty, without recourse to Seller. Buyer must give Seller notice in writing of any alleged defect covered by this warranty (together with all identifying details, including the serial number, the type of equipment, and the date of purchase) within thirty (30) days of the discovery of such defect during the warranty period. No claim made more than 30 days after the expiration of the warranty period shall be valid. Guarantees of performance and warranties are based on the use of original equipment manufactured (OEM) replacement parts. Seller assumes no responsibility or liability if alterations, non-authorized design modifications and/or non-OEM replacement parts are incorporated. If requested by Seller, any equipment (or its component parts) must be promptly returned to Seller prior to any attempted repair, or sent to an authorized service station designated by Seller, and Buyer shall prepay all shipping expenses. Seller shall not be liable for any loss or damage to goods in transit, nor will any warranty claim be valid unless the returned goods are received intact and undamaged as a result of shipment. Repaired or replaced material returned to customer will be shipped F.O.B., Seller's factory. Seller will not give Buyer credit for parts or equipment returned to Seller, and will not accept delivery of any such parts or equipment, unless Buyer has obtained Seller's approval in writing. The warranty extends to repaired or replaced parts of Seller's manufacture for ninety (90) days or for the remainder of the original warranty period applicable to the equipment or parts being repaired or replaced, whichever is greater. This warranty applies to the repaired or replaced part and is not extended to the product or any other component of the product being repaired. Repair parts of its own manufacture sold after the original warranty period are warranted for a period of one (1) year from shipment against defects in materials and workmanship under normal use and service. This warranty applies to the replacement part only and is not extended to the product or any other component of the product being repaired. Seller may substitute new equipment or improve part(s) of any equipment judged defective without further liability. All repairs or services performed by Seller, which are not covered by this warranty, will be charged in accordance with Seller's standard prices then in effect.

THIS WARRANTY IS THE SOLE WARRANTY OF SELLER AND SELLER HEREBY EXPRESSLY DISCLAIMS AND BUYER WAIVES ALL OTHER WARRANTIES EXPRESSED, IMPLIED IN LAW OR IMPLIED IN FACT, INCLUDING ANY WARRANTIES OF MERCHANTABILITY OR FITNESS FOR A PARTICULAR PURPOSE. Seller's sole obligation under this warranty shall be, at its option, to repair or replace any equipment (or its component parts) which has a defect covered by this warranty, or to refund the purchase price of such equipment or part. Under the terms of this warranty, Seller shall not be liable for (a) consequential, collateral, special or liquidated losses or damages; (b) equipment conditions caused by normal wear and tear, abnormal conditions of use, accident, neglect, or misuse of said equipment; (c) the expense of, and loss or damage caused by, repairs or alterations made by anyone other than the Seller; (d) damage caused by abrasive materials, chemicals, scale deposits, corrosion, lightning, improper voltage, mishandling, or other similar conditions; (e) any loss, damage, or expense relating to or resulting from installation, removal or reinstallation of equipment; (f) any labor costs or charges incurred in repairing or replacing defective equipment or parts, including the cost of reinstalling parts that are repaired or replaced by Seller; (g) any expense of shipment of equipment or repaired or replacement parts; or (h) any other loss, damage or expense of any nature.

The above warranty shall not apply to any equipment which may be separately covered by any alternate or special warranties.

PERFORMANCE: In the absence of Certified Pump Performance Tests, equipment performance is not warranted or guaranteed. Performance curves and other information submitted to Buyer are approximate and no warranty or guarantee shall be deemed to arise as a result of such submittal. All testing shall be done in accordance with Seller's standard policy under Hydraulic Institute procedures.

LIABILITY LIMITATIONS: Under no circumstances shall the Seller have any liability under the Order or otherwise for liquidated damages or for collateral, consequential or special damages or for loss of profits, or for actual losses or for loss of production or progress of construction, regardless of the cause of such damages or losses. In any event, Seller's aggregate total liability under the Order or otherwise shall not exceed the contract price.

ACTS OF GOD: Seller shall in no event be liable for delays in delivery of the equipment or other failures to perform caused by fires, acts of God, strikes, labor difficulties, acts of governmental or military authorities, delays in transportation or procuring materials, or causes of any kind beyond Seller's control.

COMPLIANCE WITH LAW: Seller agrees to comply with all United States laws and regulations applicable to the manufacturing of the subject equipment. Such compliance shall include: The Fair Labor Standards Acts of 1938, as amended; Equal Employment Opportunity clauses of Executive Order 11246, as amended; Occupational Safety and Health Act of 1970 and the standards promulgated thereunder, if applicable. Since compliance with the various Federal, State, and Local laws and regulations concerning occupational health and safety, pollution or local codes are affected by the use, installation and operation of the equipment and other matters over which Seller has no control, Seller assumes no responsibility for compliance with those laws and regulations, whether by way of indemnity, warranty, or otherwise. It is incumbent upon the Buyer to specify equipment which complies with local codes and ordinances.



800 Airport Road
North Aurora, Illinois 60542
630-859-7000
www.aurorapump.com