



EVERPURE® HIGH FLOW CSR PLUS – XC² WITH LPA AND TANK

DELIVERS PREMIUM QUALITY WATER FOR COMBINATION APPLICATIONS

High Flow CSR Plus-XC² w/LPA: EV9347-21
XC² Replacement Cartridge: EV9613-10
EC210 Prefilter Cartridge: EV9534-26
SS-IMF Cartridge: EV9799-32
Tank, 9-gallon: EV3065-20



APPLICATIONS

For Multiple Equipment
Combination Applications
High-Volume Installations

XC² Cartridges Provided For
Additional Capacity

FEATURES • BENEFITS

One system provides premium quality water to high flow fountain, coffee and ice machines

Reduces chlorine taste & odor and other offensive contaminants that can adversely affect the taste of beverages

Proprietary Micro-Pure® II filtration media effectively inhibits the growth of bacteria on the filter media that can decrease product life

Exclusive submicron technology provides superior chlorine taste & odor reduction and micro-filters dirt and particles as small as 0.5 micron in size by mechanical means

Ideal where extreme water conditions demand larger capacity filters and surge tank to meet peak demand flow requirements

Remote mounted SR-X System with SS-IMF Cartridge inhibits limescale buildup in ice machines and coffee brewers

20" prefilter captures larger dirt particles

Low pressure alarm signals to notify when cartridges need changing

NSF/ANSI Standard 53 certified to reduce cysts such as *Cryptosporidium* and *Giardia* by mechanical means

INSTALLATION TIPS

Choose a mounting location suitable to support the full weight of the system when operating.

Use 3/4" water line.

Fountain equipment connections are made to the outlet part of the system before the SR-X System.

Coffee brewer and ice machine connections are made after the SR-X Feeder; a tee is required.

Install vertically with cartridges hanging down. Allow 2½" (6.35 cm) clearance below the cartridge for easy replacement.

Flush cartridges by running water through system for five (5) minutes at full flow.

OPERATION TIPS

Change cartridges on a regular six (6) month preventative maintenance program.

Change cartridges when capacity is reached or when pressure falls below 10 psi (0.7 bar).

Change SS-IMF Cartridge before Hydroblend compound is completely used up.

Change prefilter cartridge when excessively dirty.

Always flush the filter cartridge at time of installation and cartridge change.

SIZING

Rated Capacity: 48,000 gallons (181,699 L)

Service Flow Rate: Maximum 6.7 gpm (25.4 Lpm)

EVERPURE® HIGH FLOW CSR PLUS – XC² WITH LPA AND TANK

EV9347-21

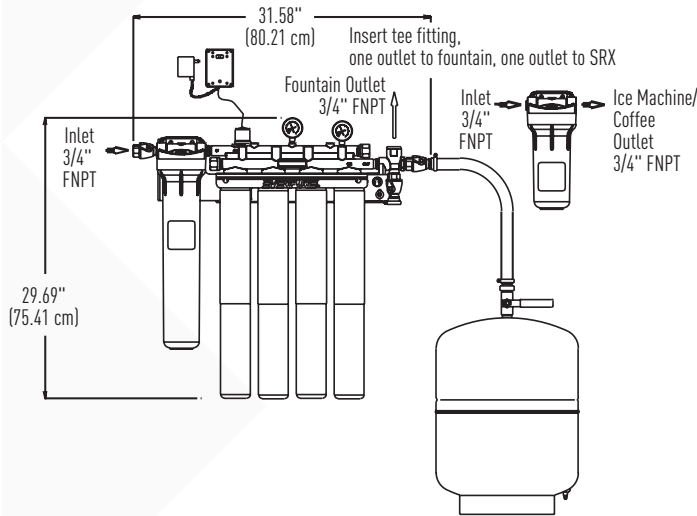

System Tested and Certified by NSF International against NSF/ANSI Standards 42 and 53 for the reduction of:

STANDARD NO. 42 – AESTHETIC EFFECTS

- Chemical Reduction
 - Taste & Odor
 - Chlorine
- Mechanical Filtration
 - Nominal Particulate Class I

STANDARD NO. 53 – HEALTH EFFECTS

- Mechanical Filtration
 - Cyst



SPECIFICATIONS

Service Flow Rate

Maximum 6.7 gpm [25.4 Lpm]

Rated Capacity

48,000 gallons [181,699 L]

Pressure Requirements

10 – 125 psi [0.7 – 8.6 bar], non-shock

Temperature

35 – 100°F [2 – 38°C]

Electrical Connection

110 V for Low Pressure Alarm

Overall Dimensions

29.69" H x 31.58" W x 6.75" D
[75.4 cm x 80.2 cm x 17.1 cm]
(excludes tank and SR-X)

Connections

Inlet Connection: 3/4" NPT

Outlet Connection: 3/4" NPT

Shipping Weight

Box 1- System: 42 lbs [19.1 kgs]

Box 2 – Surge tank: 28 lbs [12.8 kgs]

Operating Weight

System – 50 lbs [22.6 kgs]

Surge tank – 60 lbs [27.2 kgs]

EPA Est. No. 002623-IL-002

The contaminants or other substances removed or reduced by this drinking water system are not necessarily in your water. Do not use with water that is microbiologically unsafe or of unknown quality without adequate disinfection before or after the system. Systems certified for cyst reduction may be used with disinfected water that may contain filterable cysts.

WARRANTY

Everpure water treatment systems by Pentair® (excluding replaceable elements) are covered by a limited warranty against defects in material and workmanship for a period of five years after date of purchase. Everpure replaceable elements (filter cartridges and water treatment cartridges) are covered by a limited warranty against defects in material and workmanship for a period of one year after date of purchase. See printed warranty for details. Pentair will provide a copy of the warranty upon request.



WATER QUALITY SYSTEMS

EVERPURE-SHURFLO WORLD HEADQUARTERS, 1040 MUIRFIELD DRIVE, HANOVER PARK, IL 60133 USA • FOODSERVICE.PENTAIR.COM
800.942.1153 (US ONLY) • 630.307.3000 MAIN • 630.307.3030 FAX • CSEVERPURE@PENTAIR.COM EMAIL

EVERPURE-SHURFLO AUSTRALIA, 1-21 MONASH DRIVE, DANDENONG SOUTH, VIC 3175 AUSTRALIA
011.1300 576 190 TEL • 011.61.39.562.7237 FAX • AU.EVERPURE@PENTAIR.COM EMAIL

EVERPURE-SHURFLO CHINA, 21F CLOUD 9 PLAZA, NO 1118, SHANGHAI, 200052, CHINA
86.21.3211.4588 TEL • 86.21.3211.4580 FAX • CHINA.WATER@PENTAIR.COM EMAIL

EVERPURE-SHURFLO INDIA, GREEN BOULEVARD, B-9/A, 7TH FLOOR - TOWER B SECTOR 62, NOIDA - 201301
91.120.419.9444 TEL • 91.120.419.9400 FAX • INDIACUSTOMER@PENTAIR.COM EMAIL

EVERPURE-SHURFLO EUROPE, PENTAIR WATER BELGIUM BVBA, INDUSTRIEPARK WOLFSTEE, TOEKOMSTLAAN 30, B-2200 HERENTALS, BELGIUM
+32.(0).14.283.504 TEL • +32.(0).14.283.505 FAX • SALES@EVERPURE-EUROPE.COM EMAIL

EVERPURE-SHURFLO JAPAN INC., HASHIMOTO MN BLDG. 7F, 3-25-1 HASHIMOTO, MIDORI-KU, SAGAMIHARA-SHI KANAGAWA 252-0143, JAPAN
81.(0)42.775.3011 TEL • 81.(0)42.775.3015 FAX • INFO@EVERPURE.CO.JP EMAIL

EVERPURE-SHURFLO SOUTHEAST ASIA, 390 HAVELOCK ROAD, #04-01 KING'S CENTRE, SINGAPORE 169662
65.6768.5800 TEL • 65.6737.5149 FAX • CSEVERPURE@PENTAIR.COM EMAIL

All Pentair trademarks and logos are owned by Pentair, Inc. or its affiliates. All other registered and unregistered trademarks and logos are the property of their respective owners. Because we are continuously improving our products and services, Pentair reserves the right to change specifications without prior notice. Pentair is an equal opportunity employer.